

SHM

safe seas, safe shores

Product Catalogue

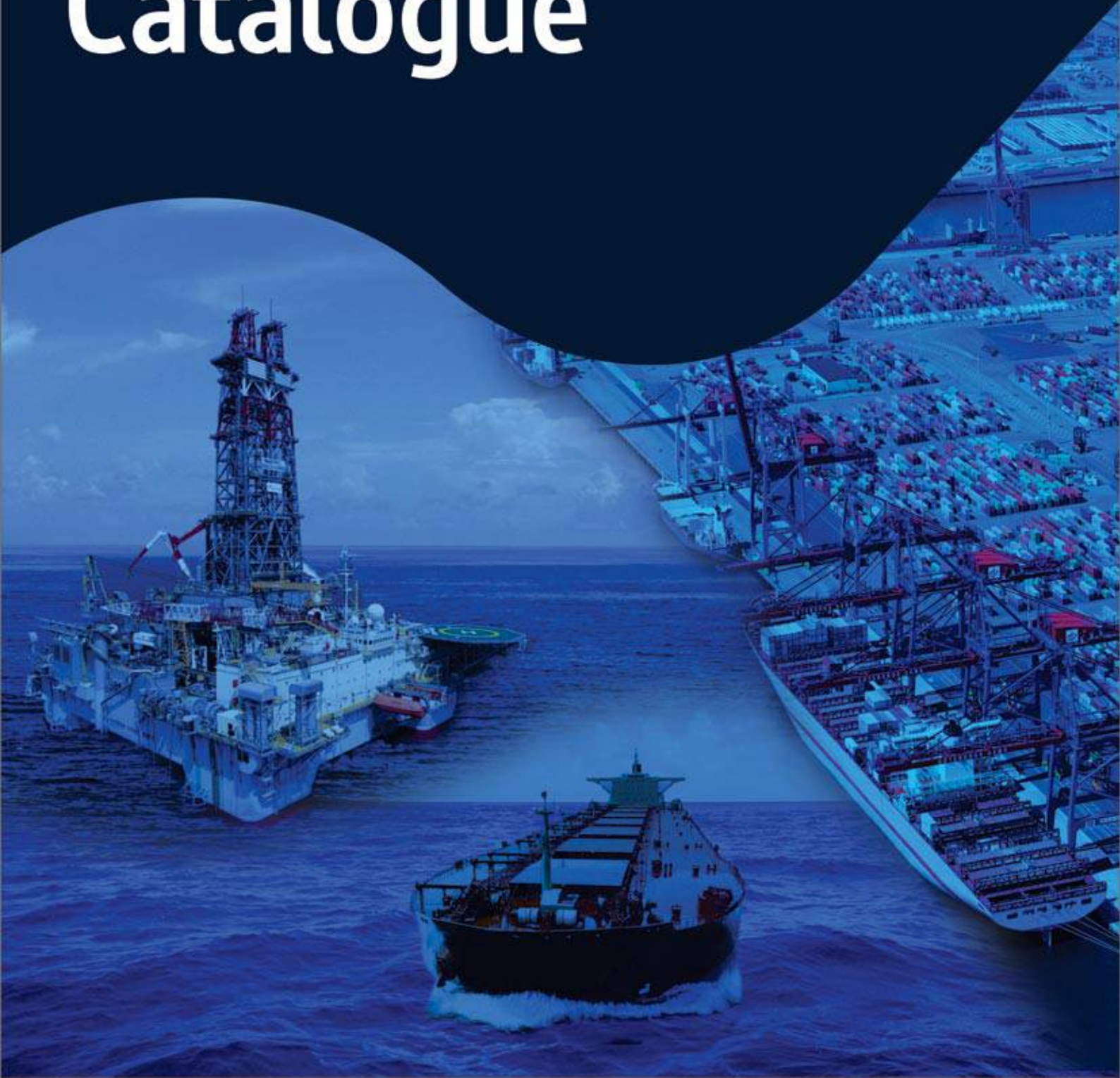

100 years of family business to establish credibility

The Hajee family began its marine safety business in 1885. Today, we look back proudly on our heritage of more than 100 years of family business operating in the marine and offshore industry. Our family values drive the way we do business and we've built our company on caring for the lives of our people. It's important to us that our people at sea are safe and feel protected at all times.

With an ambition to reach new markets, to continuously grow our business and raise our standards, and never settle for good enough, we're now opening a new chapter in our company's history. We look forward to the next decades of success with a new visual identity that reflects our international outlook and renewed promise of effective, responsible, and sustainable service to our clients and partners.

SHM was founded in 2001, by Chairman and industry veteran Mr. Saifuddin Hajee, with the mission to save lives through timely delivery of quality marine safety and survival systems. With its headquarters in Mumbai, SHM today has a network spanning over 18 port cities along the Indian coast, Singapore, Dubai, and Malaysia.

For more information please contact your nearest SHM office (see last page) or visit us at www.shmgroup.com

OUR MISSION

Our mission is to become the leader in creating safe and secure working environments that enable businesses' freedom at sea and on shore.

We will achieve this by partnering with our customers to increase their productivity, fuel their sustainable growth by providing the most reliable safety products and engineering solutions, and having a positive impact on the world around us and on people's lives.

INDEX

SHM Inflatable Liferaft.....	3
Marine Safety Equipment.....	5
Fire safety Equipment.....	9
Fire Extinguisher.....	11
Valves, Coupling, Nozzles and Hoses.....	15
Ikaros Pyrotechnics.....	21
Chinese Pyrotechnics.....	25
McMurdo GMDSS Equipment.....	27
Survival Craft Accessories.....	31
IMO Signs And Posters.....	35
Billy Pugh Equipment.....	39
Helicopter Crash Kit.....	41
Dura Fibreglass Cabinets.....	43
Transfer and Descent Equipments.....	47
Vecome Chemicals and Test Kit.....	51
Co2 Fire Suppression Valves and Accessories.....	55
Disposal Of Pyrotechnics.....	57

SHM

safe seas, safe shores

Throw Over-Board Liferaft



SHM's range of Throw Over-Board Liferrafts are manufactured to the highest quality standards, under close supervision of international classification societies.

Standard SOLAS Liferrafts are available in capacity of 6, 10, 15, 20 & 25 persons to suit vessel's safety plan and are designed to function in adverse sea conditions (-30°C+60°C).

The units are packed in sturdy waterproof fibre glass containers to protect the liferafts against sunlight and weather extreme conditions.

Key Features:

- Comply to SOLAS LSA Code 96 including latest amendments in the year 2010 i.e. MSC Res.218(82), 226(82), .293(87) & 295(87)).
- Approved by Directorate General of Shipping India and Ministry of Surface Transport, which are both representative bodies of the Govt. of India. EC approval under process.
- Manufactured from polyester neoprene coated fabric that complies to MSC Resolution 81/70 for excellent weather resistance and permeability.
- Two buoyancy chambers ensures that with failure of one, the other provides sufficient buoyancy to carry passengers safely.
- Drop tested for maximum stowage height of 35 meters.
- Hydrostatic quick release unit for automatic inflation.
- Installed onboard either on galvanized cradles, racks, or column stacks for storing multiple liferafts, saving valuable deck space.



Column Racks | Code: S04130
For stackable storage, saving deck space

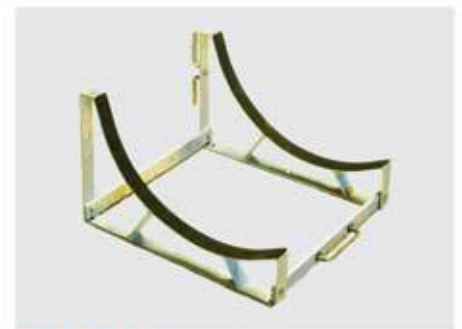

Deck Cradles | Code: S04131
For flexible storage and easy installation



Hydrostatic Release Unit | Code: S05101
Enables Liferrafts to surface and inflate when a ship is sinking

MODEL NO.	PRODUCT CODE	CAPACITY	PHYSICAL FORM	CONSTRUCTION OF CANOPY ARCH	WIDTH (mm) (A)	HEIGHT (mm) (B)	WORKING PRESSURE (in mm, wg)	CONTAINER DIMENSIONS	
								LENGTH (mm) (C)	DIAMETER (mm) (D)
A-6 (II)	S02101	6	●		2116	1220	1400	1245	520
A-10 (II)	S02102	10	◆		2720	1400	1400	1260	635
A-15 (II)	S02103	15	◆		3360	1680	1400	1420	635
A-20 (II)	S02104	20	●		3820	1900	1400	1495	737
A-25 (II)	S02105	25	●		4220	2100	1400	1495	737

Sales and Service Network



SHM has decades of experience in servicing multi-brand liferafts. Our global servicing network of trained, experienced staff offers the highest level of service with exclusive use of quality parts and equipment.

All our branches also offer servicing for Survival Crafts, Rescue Boats, Davit Systems, Inflatables, Survival Suits, EPIRBs, SARTs, Breathing Apparatus, and Fire Safety Equipment, which are approved by all major classification societies.

For more information please contact your nearest SHM office or visit us at www.shmgroup.com

Inflatables Production Facility :

145 (old no. 74), East Mada Church Street, Royapuram, Chennai - 600 013. | T: 91 44 2590 1322 / 1679 | F: 91 44 4217 3327



safe seas, safe shores

Guardian SOLAS Lifejackets

SHM's Guardian series lifejackets are specially manufactured to be easily worn & are fully compliant with the SOLAS LSA code. They come in adult and child sizes, and are recommended to combine with the SHM Pulse J1 Lifejacket Light.

Guardian A1



Lifejacket - Adult

- Code : L01101
- Size : Adult Universal, Oversize persons
- Material : Polyester Oxford Fabric, EPE Foam
- Buoyancy : > 150N
- Size of wearer : up to 140Kg with a chest girth of 175 cm
- Accessories : Emergency light (optional), whistle, buddy line, & lifting loop
- Operating temp: -30°C to +65°C

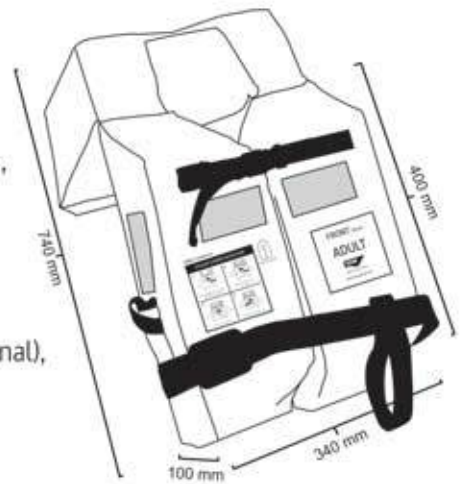

Guardian C1



Lifejacket - Child

- Code : L01102
- Size : Child
- Material : Polyester Oxford Fabric, EPE Foam
- Buoyancy : > 88N
- Size of wearer : 15 Kg to 43 Kg
- Accessories : Emergency light (optional), whistle, buddy line, & lifting loop
- Operating temp: -30°C to 65°C



Accessories

Whistle



Code : S04125

RR Tape



Code : S04120

Lifejacket Storage box



Capacity 15 adult lifejackets

Code : D01106

Lifejacket Light



Pulse J1

Code : L02101

SHM

safe seas, safe shores

SOLAS Lifebuoys

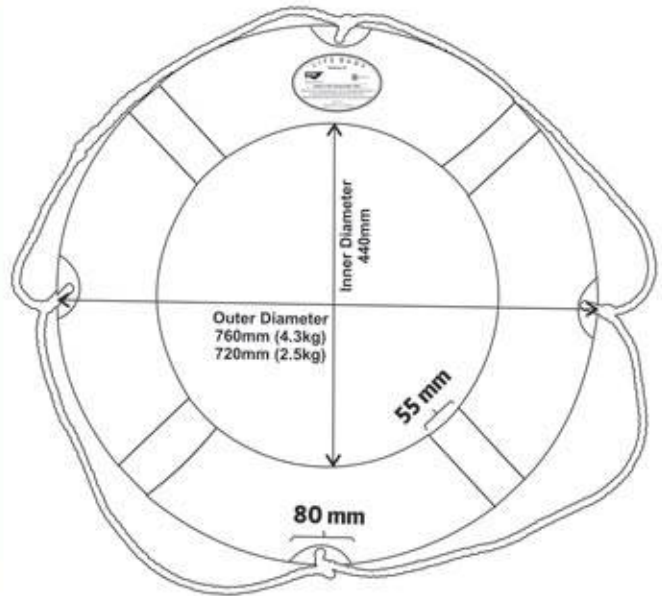

Safebuoy 25

Safebuoy 43

Code	L03101	L03102
Weight	2.5 kg	4.3 kg
Material	HDPE Crust filled with PU Frothing	HDPE Crust filled with PU Frothing
Buoyancy	> 150N	> 150N
Drop Height	80m	80m
Grab Line	Polyethylene	Polyethylene

Directions for use of MOB with Safebuoy 43

Method 1



Remove lifebuoy



Throw lifebuoy

Method 2



Pull out lock pin



Lifebuoy pulls MOB

Accessories

Floating Line



Code : S04102

SS Bracket



Code : L03103

Quick Release Case

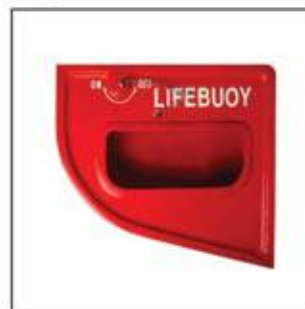

Code : L03104

Lifebuoy Light



Code : L04101

Pulse B1

SHM

safe seas, safe shores

Pulse J1



Lifejacket Light

Code	: L02101
Light	: LED Type, water activated
Duration Cycle	: 8 hrs
Flashing frequency	: 50 to 70 times/min
Battery	: Lithium battery
Shelf life	: 5 Years
Design	: Lightweight, waterproof, and compact
Operating temp	: -30°C to +65°C

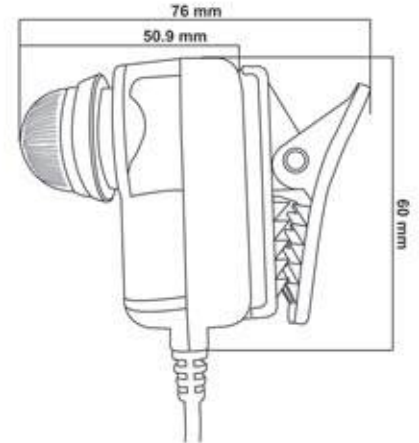

Pulse B1



Lifebuoy Light

Code	: L04101
Light	: LED Type white light, water activated
Duration Cycle	: > 2 hrs
Flashing frequency	: 50 to 70 times/min
Battery	: Lithium battery
Shelf life	: 5 Years
Operating temp	: -30°C to +65°C
Luminous Intensity	: > 2 cd

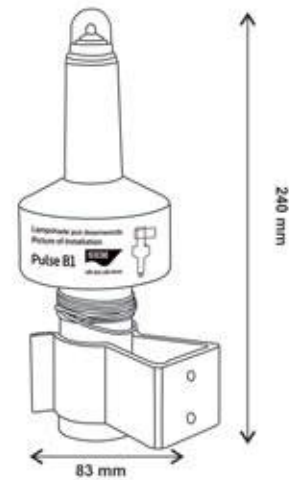

Therma T1



Thermal Protective Aid

Code	: L06101
Material	: Polyester coated aluminium composite fabric
Usage	: Reduces evaporative heat loss from user's body
Operating Temp	: -30°C to +65°C

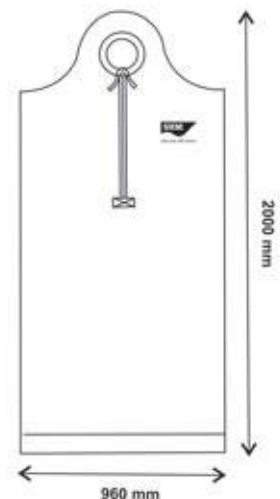

SHM

safe seas, safe shores

Crimson I1



SHM's Crimson range of Immersion Suits are designed, in accordance to SOLAS LSA code, to improve the ability to remain dry and maintain body temperature when immersed in water. Crimson I1 suits are made of reinforced neoprene, and come in assorted sizes with a head support.

Immersion Suit

Size : S,M,L,XL
Code : L05101
Material : Neoprene
Buoyancy : > 160 N
Whistle : Yes
Light : Yes
Reflective Tape : 400 cm²
Operating temp : -30°C to +65°C

Immersion Suit Testing Kit



Code : L05103

The kit comprises of:

1. Face fixture
2. Pressure Gauge
3. Glue and Applicator
4. Foot Pump

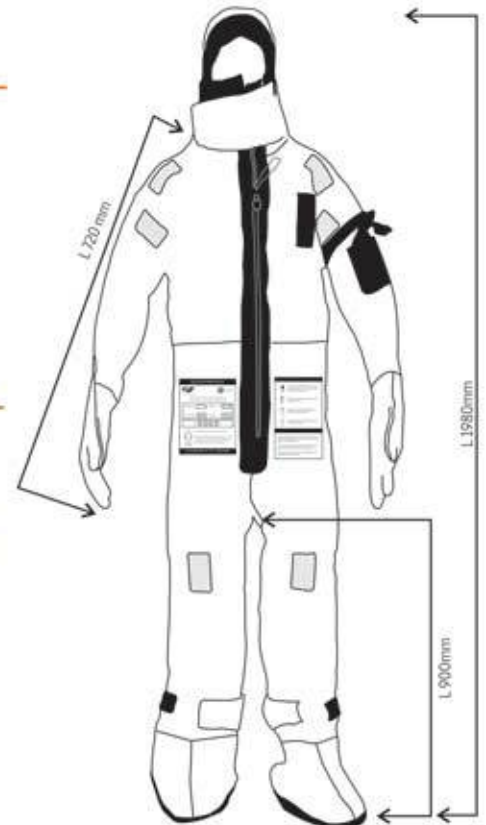

* Dimension for L Size

Accessories

Emergency Light



Code : L11102

Whistle



Code : S04125

Watertight Zip



Code : L05102

RR Tape



Code : S04120

Vulcan F1 Fireman's Outfit

SHM's Vulcan F1 Fireman's outfit, complying to SOLAS standards, has been designed to provide protection from the exposure of heat in the event of a fire. The outfit consists of a heat insulation suit, constructed from flame-resistant aramid fabric with aluminum coating, pair of gloves, helmet with visor, fire hood, rubber boots and accessories.



Fire Suit Jacket
Code : F04102



Fire Suit Trousers
Code : F04103



Fireman's Gloves
Code : F04104



Fireman's Helmet with Visor
Code : F04107



Fireman's Boots
Code : F04106



Code: F04101



Fire Suit Hood
Code : F04105



Fireman's Waistbelt
Code : F04108



Axe with Insulated Handle
Code : F04109



Axe Pouch
Code : F04110



Axe with Long Wooden Handle
Code : F04111



Fire Proof Line
Code : F04112 | F04113



Explosion Proof Torch
Code : F04114 | F04115



safe seas, safe shores

Aether Self Contained Breathing Apparatus



Key Features

Aether self-contained open-circuit compressed air breathing apparatus, complying to SOLAS standards, is designed to provide respiratory protection from toxic gases and smoke to the user, while entering or escaping a hazardous environment. The complete set includes a face mask, demand valve, backplate with harness, cylinder and regulator.

Aether SBA-6/30

- Product Code : F06101
- Cylinder Volume : 6 L
- Air Capacity : 1,800 L
- Working Pressure : 300 Bar
- Service Time : 55-60 mins
- Alarm Pressure : 40-60 Bar
- Weight : ≤18 kg

Carrying Case



Code : F06112

Cylinder & Valve	Pressure Tester	Face Mask	Backplate & Harness	Demand Valve
				
F06109 F06108	F06111	F06102	F06106	F06104

Aether Emergency Escape Breathing Device



Key Features

Aether EBD's are used to safely evacuate from a dangerous environment that lacks normal breathing conditions. Such situations arise from smoke caused by fire, gas leaks, etc. The complete set includes a face hood connected to the cylinder in a carry case and complies to SOLAS standards.

Aether EBD - 10

Aether EBD - 15

	Aether EBD - 10	Aether EBD - 15
Product Code	F08101	F08102
Air Capacity	2 L	3 L
Air Flow (L/Min)	≥35	≥35
Working Pressure	210 Bar	210 Bar
Service Time	≥10 mins	≥15 mins
Alarm Pressure	40-60 Bar	40-60 Bar
Weight	≤6 kg	≤8.5 kg
Working Temperature	-10°C + 65°C	-10°C + 65°C

Face Hood	Cylinder Valve	Spare Cylinder	Refilling Adapter
			
F08105	F08104	F08106 F08107	F08103

safe seas, safe shores

Stored Pressure Type Fire Extinguishers



MODEL	PF-ABC 2S	PF-ABC 4S	PF-ABC 6S	PF-ABC 9S
Product Code	F02111	F02112	F02113	F02114
Specification	IS 15683 : 2006	IS 15683 : 2006	IS 15683 : 2006	IS 15683 : 2006
Capacity (kg)	2 kg	4 kg	6 kg	9 kg
Body Material	Mild Steel Sheet	Mild Steel Sheet	Mild Steel Sheet	Mild Steel Sheet
Body Sheet Thickness (mm)	1.5 mm	1.5 mm	1.5 mm	1.5 mm
Extinguishing Agent	Dry Powder (MAP) IS: 14609	Dry Powder (MAP) IS: 14609	Dry Powder (MAP) IS: 14609	Dry Powder (MAP) IS: 14609
Fire Rating	1 A:8B	1A:13B	3A:21B	3A:34B
Propellant	Nitrogen	Nitrogen	Nitrogen	Nitrogen
Discharge Time (Minimum)	8 sec.	13 sec.	13 sec.	13 sec.
Dimensions OD (mm)	110 mm ± 10 mm	140 mm ± 10 mm	150 mm ± 10 mm	175 mm ± 10 mm
Empty Weight (Approx)	1.4 kg.	2.7 kg.	3 kg.	4.18 kg.
Filled Weight (Approx)	3.4 kg.	6.7 kg.	9 kg.	13.18 kg.
Discharge Throw (Minimum)	2 mtr	4 mtr	4 mtr	4 mtr
Operating Temperature	-30°C to +55°C	-30°C to +55°C	-30°C to +55°C	-30°C to +55°C
Working Pressure	15 Bar	15 Bar	15 Bar	15 Bar
Hydraulic Test Pressure	35 Bar	35 Bar	35 Bar	35 bar

Stored Pressure Fire Extinguishers are available with 50% & 90% Mono Ammonium Phosphate Powder



safe seas, safe shores

Cartridge Type Fire Extinguishers



FIRE EXTINGUISHERS



MODEL	PF-BC 4C	PF-BC 6C	PF-BC 9C	PF-F 9C	PF-W 9C
Product Code	F02101	F01101	F01102	F01103	F01104
Specification	IS 15683 : 2006	IS 15683 : 2006	IS 15683 : 2006	IS 15683 : 2006	IS 15683 : 2006
Capacity (kg)	4 kg	6 kg	9 kg	9 Ltr.	9 Ltr.
Body Material	Mild Steel Sheet	Mild Steel Sheet	Mild Steel Sheet	Mild Steel Sheet	Mild Steel Sheet
Body Sheet Thickness (mm)	1.5 mm	1.5 mm	1.5 mm	1.5 mm	1.5 mm
Extinguishing Agent	ISI Marked SBC Powder	ISI Marked SBC Powder	ISI Marked SBC Powder	6% AFFF Solution	Water
Fire Rating	21 B	21 B	34 B	3A : 34 B	3A
Propellant	120 gms CO2 Gas Cartridge	120 gms CO2 Gas Cartridge	200 gms CO2 Gas Cartridge	90 gms CO2 Gas Cartridge	90 gms CO2 Gas Cartridge
Discharge Time (Minimum)	13 sec	13 sec	13 sec	13 sec	13 sec
Dimensions OD (mm)	145 mm ± 10mm	160 mm ± 10mm	190 mm ± 10mm	190 mm ± 10mm	190 mm ± 10mm
Empty Weight (Approx)	4.2 kg	4.9 kg	5.6 kg	5 kg	5.7 kg
Filled Weight (Approx)	8.2 kg	10.9 kg	14.6 kg	15.9 kg	14.7 kg
Discharge Throw (Minimum)	4 mtr.	4 mtr.	4 mtr.	4 mtr.	4 mtr.
Operating Temperature	-30°C to +55°C	-30°C to +55°C	-30°C to +55°C	+5°C to +55°C	+5°C to +55°C
Working Pressure	15 Bar	15 Bar	15 Bar	15 Bar	15 Bar
Hydraulic Test Pressure	35 Bar	35 Bar	35 Bar	35 Bar	35 Bar

Co2 & Wheeled Type Fire Extinguishers



PF-CO 2	PF-CO 4	PF-CO 6	PF-CO 9	PF-CO 22	PF-F 50 C
F02106	F01105	F01106	F01107	F01108	F01109
IS 15683 : 2006	IS 15683 : 2006	IS 2878 : 2004	IS 2878 : 2004	IS 2878 : 2004	IS 13386
2 kg	4.5 kg	6.5 kg	9 kg	22.5 kg	50 Ltr.
Mild Steel	Mild Steel	Mild Steel	Mild Steel	Mild Steel	Mild Steel Sheet
4.5 mm	4.5 mm	4.5 mm	4.5 mm	5.2 mm	1.5 mm
Liquified CO2	Liquified CO2	Liquified CO2	Liquified CO2	Liquified CO2	6% AFFF Solution
8 B	13 B	55 B	70 B	89 B	-
-	-	-	-	-	300 Gms Co2 Gas Cartridge
8 sec	10 sec	10 sec	15 sec	20 sec	40 sec
110 mm ± 10mm	139 mm ± 10 mm	139 mm ± 10mm	139 mm ± 10mm	230 mm ± 10mm	290 mm ± 10mm
6.2 kg	12.6 kg	14.5 kg	20 kg	44.6 kg	37.6 kg
8.2 kg	17.1 kg	21 kg	29 kg	67.1 kg	87.6 kg
1 mtr.	2 mtr.	-	-	-	10 mtr.
-30°C to +55°C	-30°C to +55°C	-30°C to +55°C	-30°C to +55°C	-30°C to +55°C	+5°C to +55°C
50 Bar	50 Bar	50 Bar	50 Bar	50 Bar	15 Bar
250 Bar	250 Bar	250 Bar	250 Bar	250 Bar	30 Bar



safe seas, safe shores

Automatic Fire Extinguisher



SHM brand of modular fire extinguishers provide an automatic detection and suppression system in a single unit. The modular fire extinguisher are available with dry chemical powder (MAP 50% & 90%) and clean agent gases in 2 kg, 5 kg, 10 kg and 15 kg capacities.

The fire extinguisher consists of a  approved temperature sensitive bulb of 68°C temperature rating. The presence of a pressure gauge provides an instant verification of functionality and reliability of every unit.

The modular fire extinguishers are ideal for use in server rooms, factories and un manned areas.

Portable Foam Applicator



The Portable Foam Applicator Unit acts as a supplement to the foam monitors. This unit provides high level of flexibility for extinguishing fire in the Marine & Offshore environment in sheltered areas where the reach of foam monitors are limited. The complete unit consists of:

- Stainless Steel 316 grade 20 litres portable tank
- FB 5X Foam making Branch Pipe along with pick up tube
- 63mm x 7.5 meters IRS/Wheelmark approved Type A hose fitted with IRS approved Gunmetal coupling bound with copper wire
- 20 Ltrs. ISI marked AFFF solution in jerry can

Prodct Code: F10101



safe seas, safe shores

Fire Hydrant Valves

SHM offers a comprehensive range of fire hydrant valves catering to the customers requirements. These valves are manufactured from LTB2 Gunmetal to ensure resistance to corrosion. The primary patterns that we manufacture are Right Angle, Horizontal, Oblique, and Big Nose type with flanged and threaded inlets. Our Fire Hydrant Valves are manufactured in accordance to international standards & SOLAS regulations, and are available with single and double lug assembly with Instantaneous, Nakajima and Storz connections.

Oblique Hydrant Valve



Oblique Type 1½"	:	F12137
Oblique Type 2"	:	F12138
Oblique Type 2½"	:	F12139

Right Angle Hydrant Valve



Right Angle Type 1½"	:	F12140
Right Angle Type 2"	:	F12141
Right Angle Type 2½"	:	F12142

Horizontal Hydrant Valve



Horizontal Type 1½"	:	F12143
Horizontal Type 2"	:	F12144
Horizontal Type 2½"	:	F12145

Double Headed Hydrant



Double Headed Type 1½"	:	F12146
Double Headed Type 2"	:	F12147
Double Headed Type 2½"	:	F12148

Bib Nose Hydrant Valve



Bib Nose Type 1½"	:	F12149
Bib Nose Type 2"	:	F12150
Bib Nose Type 2½"	:	F12151

Fire Hydrant Accessories



Blank Cap with Chain for Instantaneous Hydrant Valve

	PVC	Metal
1½"	F12158	F12164
2"	F12159	F12165
2½"	F12160	F12166

Rubber Washer for Instantaneous Hydrant Valve

1½"	F12152	
2"	F12153	
2½"	F12154	

Fire hydrant blank caps and rubber washer are available to suit various international connections upon request.

Fire Hoses

SHM's offer highly durable fire hoses for use in the marine and offshore environment. The hoses are available from 1.5" to 2.5" diameter in standard lengths of 15m, 20m & 30m. Other lengths are available upon request. The hoses comply to SOLAS regulations and are MED approved.

Hose with PVC Lining



100% Virgin High Tenacity Polyester Jacket with PVC Tube Lining

Code : F131

White Color

15 Bar Service Pressure

45 Bar Minimum Burst Pressure

Hose with EPDM Lining



100% Virgin High Tenacity Polyester Jacket with EPDM Tube Lining

Code : F132

White Color

15 Bar Service Pressure

45 Bar Minimum Burst Pressure

Heavy Duty Fire Hose



Synthetic Yarn Reinforcement with Ribbed Outer Lining Surface

Code : F133

Red Color

Nitrile and PVC blend inner lining with ribbed outer lining surface for higher resistance to heat and abrasion.

Fire Hose Storage Units

As per the client's requirements, we can provide FRP, Stainless Steel and Mild Steel cabinets and baskets for storage of fire hoses, couplings, and nozzles on board ships and offshore platforms.

FRP Fire Hose Cabinet



MS & SS Fire Hose Cabinet



Fire Hose Basket

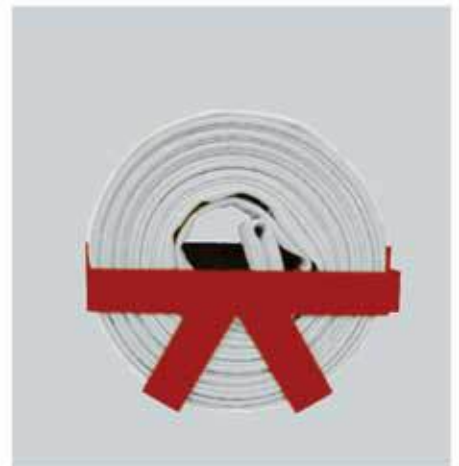

Fire Hose & Storage Units are available as per your requirements through SHM's global distribution network



safe seas, safe shores

Fire Hose Couplings

SHM's range of Hose Couplings are made from Gunmetal alloy, thereby ensuring a longer performance life. We manufacture the couplings with connections as per international designs and standards i.e., Instantaneous, Nakajima, Storz, etc.

Instantaneous Coupling



Instantaneous Coupling 1 1/2"	:	F12101
Instantaneous Coupling 2"	:	F12102
Instantaneous Coupling 2 1/2"	:	F12103

Storz Coupling



Storz Coupling 1 1/2"	:	F12104
Storz Coupling 2"	:	F12105
Storz Coupling 2 1/2"	:	F12106

Nakajima Coupling



Nakajima Coupling 1 1/2"	:	F12107
Nakajima Coupling 2"	:	F12108
Nakajima Coupling 2 1/2"	:	F12109

Camlock Coupling



Camlock Coupling 1 1/2"	:	F12110
Camlock Coupling 2"	:	F12111
Camlock Coupling 2 1/2"	:	F12112

Coupling Spanners



	Storz	Nakajima
Spanner 1 1/2"	F12134	F12131
Spanner 2"	F12135	F12132
Spanner 2 1/2"	F12136	F12133

Coupling Adaptors



Adaptors available to suit various international coupling connections upon request.

Jet Spray Fire Nozzles

SHM's Nozzles are available with a range of coupling connections such as Instantaneous, Nakajima, Storz, etc. These Nozzles have jet and spray applications along with shutoff. Being manufactured from Gunmetal alloy ensures a longer performance life and resistance to corrosion.

Instantaneous Nozzle



Instantaneous Nozzle 1½"	:	F12113
Instantaneous Nozzle 2"	:	F12114
Instantaneous Nozzle 2½"	:	F12115

Storz Nozzle



Storz Nozzle 1½"	:	F12116
Storz Nozzle 2"	:	F12117
Storz Nozzle 2½"	:	F12118

Nakajima Nozzle



Nakajima Nozzle 1½"	:	F12119
Nakajima Nozzle 2"	:	F12120
Nakajima Nozzle 2½"	:	F12121

International Shore Connection

The International Shore Connection is a universal hose connection that is to be provided on all ships as per the SOLAS requirement. When there is a total failure of pumps aboard a vessel, this hose connection enables its attachment to pumps on land or on another vessel. These connections are manufactured from LTB 2 alloy ensuring resistance to corrosion.

Instantaneous Connection



Instantaneous Type 1½"	:	F12122
Instantaneous Type 2"	:	F12123
Instantaneous Type 2½"	:	F12124

Storz Connection



Storz Type 1½"	:	F12125
Storz Type 2"	:	F12126
Storz Type 2½"	:	F12127

Nakajima Connection

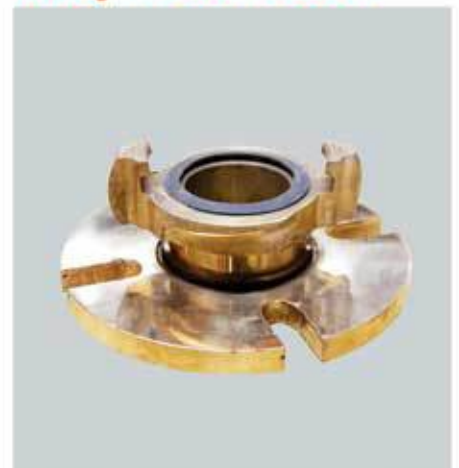

Nakajima Type 1½"	:	F12128
Nakajima Type 2"	:	F12129
Nakajima Type 2½"	:	F12130



safe seas, safe shores

Unifire Fire Nozzles

The Unifire V-nozzles are multi-purpose fog nozzle having a high performance for both fog and jet. These nozzles are available in both long and short version and can be combined with an attachable foam tube for heavy and medium foam.



The Unifire V-nozzle are available in size 7, 10, 12, 14, 16, 18, & 20

Operation

Simply twist the nozzle head to select spray-pattern. Stepless adjustable from shut-off via jet to 90° fog.

Application

Fire extinguishing with fog or jet. Proven very reliable and designed for heavy professional use in Offshore & Marine environment.

Material

Chromeplated brass, red plastic cover & rubber bumper head.

- 1. Friction Cover.....Chromeplated Brass
- 2. Maneuvering.....Chromeplated Brass
- 3. Center.....Chromeplated Brass
- 4. O-ringsNitrile Rubber
- 5. Rubber Head.....High Quality Rubber

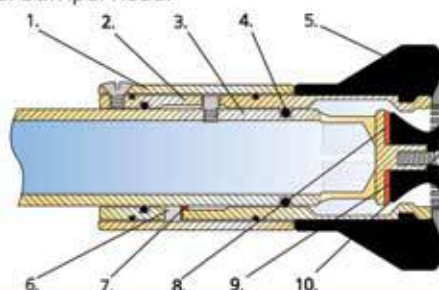

- 6. Oil.....Silicone Oil
- 7. Max Fog Fix.....Brass
- 8. SealVulkolan
- 9. Baffle.....Delrin
- 10.Screws(ALL).....Stainless Steel

Approvals

Nozzles are approved by: Lloyds, Det Norske Veritas, Bureau Veritas, American Bureau of Shipping, etc.

Connection

1" or 2" BSP male thread (Short version 1" female)

Maintenance

Unifire nozzles are practically maintenance free. The only spare part is the baffle and its screw.

	Mini Jet		Fog 110		Full Jet		Half Jet	
Pressure Bar	Flow LPM	Range Meters	Flow LPM	Range Meters	Flow LPM	Range Meters	Flow LPM	Range Meters
6	0-55	19	310	9-15	315	31	160	28
10	0-72	25	390	17-25	370	37	190	36

Unifire Nozzles are available ex-stock through SHM's global distribution network



safe seas, safe shores

Elkhart Marine Handline Nozzles

These handline nozzles are specifically designed and manufactured for the unique firefighting challenges of a marine environment. Made from corrosion resistant cast brass construction, these nozzles are ideal for the application of AFFF.

The constant flow technology, combined with their durable construction, make them optimal for use in the shipping industry, in refineries and for off-shore drilling or production rigs, as well as within chemical complexes.



FIRE HYDRANT VALVES, HOSES, HOSE FITTINGS & ACCESSORIES



Specification

MODEL	: SFL-GCC-95
Flow Rate GPM (LPM)	: 95 (360)
Shut-Off	: Ball
Weight (Lbs.)	: 6.92
Length (Inches)	: 8.06
Approval	: FM & USCG



Specification

MODEL	: SFL-CG-95
Flow Rate GPM (LPM)	: 95 (360)
Shut-Off	: Ball
Weight (Lbs.)	: 8.25
Length (Inches)	: 8.31
Approval	: FM & USCG

Elkhart Nozzles are available ex-stock through SHM's global distribution network



safe seas, safe shores



Linethrower



Applications

For use as pilot line for cables and ropes in rescue operations at sea: between vessels, ship-to-shore, shore-to-ship, and shore based rescue services.

Design and function

A robust construction consisting of a weatherproof plastic casing, incorporating an integral handle and trigger mechanism, with a solid fuel rocket and 300m of line. A solid propellant is used which guarantees a highly accurate flight path even in strong winds. To comply with SOLAS requirements, four complete rocket and line assemblies should be carried on board.

General

The IKAROS Linethrower is approved globally and meets the latest SOLAS 74/96 regulations. To comply with SOLAS requirements, four complete rocket and line assemblies should be carried on board.

Specifications

Product Code	: P01102
Performance	: Throws a line
Lenth of Line	: 300m 4mm X 300m
Line Strength	: 2000N
Storage Temperature	: Should not exceed +75°C
Dimensions	: 340 X 230mm
Weight	: 4 kg
Validity	: 3 years

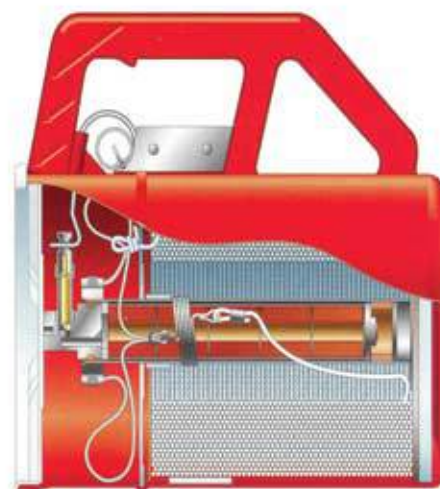

Directions for use



Remove safety pin.



Keep arrows on the line-thrower parallel to the deck/ground. Press the line-thrower against your thigh.



Pull trigger.



WARNING :

- Keep out of reach of children
- Only for emergency use at sea
- If damaged or dented do not use
- Do not dismantle
- Keep away from source of heat
- Do not use after expiry date



DISPOSAL :

- Pyrotechnics must be treated as hazardous items and must be disposed of responsibly in accordance with local regulations. For help and advice, visit our website www.shmgroup.com

safe seas, safe shores

Man-Overboard Light & Smoke



Applications

Used to mark the position of a man overboard by day or night. Ships are required to carry 2 markers, one mounted on each bridge wing with the brackets supplied and attached by line to a 4kg Lifebuoy.

Design and function

A combined day and night marker which produces dense orange smoke for 15 minutes and 2 hours of light. It comes with a lithium battery sealed for life.

General

The IKAROS MOB is a compact Lifebuoy marker that is approved globally and meets the latest SOLAS 74/96 regulations.

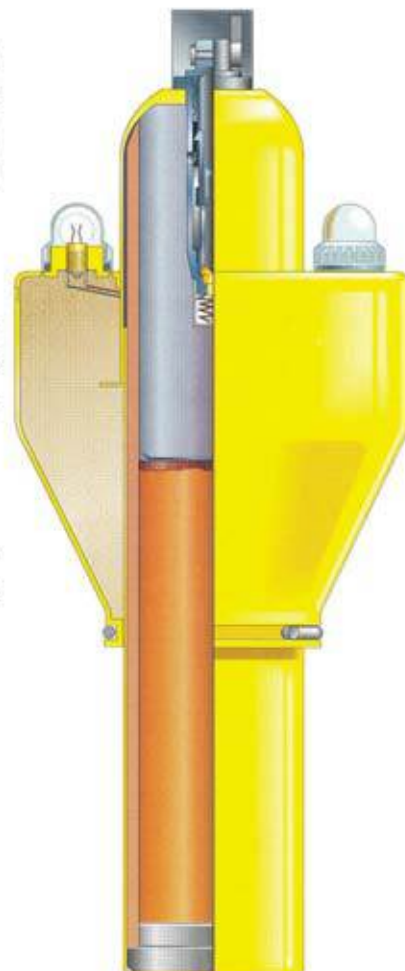

Specifications

Product Code	: P01101
Light Luminance	: 2 cd
Lights burn time	: 2 hours
Smoke time	: 15 min
Storage Temperature	: Should not exceed +75°C
Dimensions	: 200 x 500mm
Weight	: 4.6 kg
Validity	: 3 years

Directions for use

Method 1



Remove lifebuoy.



Throw lifebuoy overboard.

Method 2

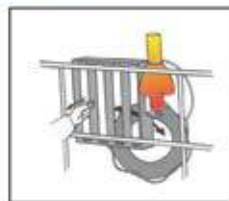

Pull out lock pin.

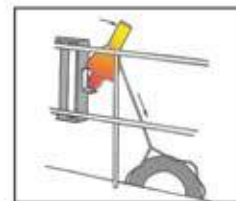

Lifebuoy pulls the signal with it.



WARNING :

- Keep out of reach of children
- Only for emergency use at sea
- If damaged or dented do not use
- Do not dismantle
- Keep away from source of heat
- Do not use after expiry date



DISPOSAL :

- Pyrotechnics must be treated as hazardous items and must be disposed of responsibly in accordance with local regulations. For help and advice, visit our website www.shmgroup.com



safe seas, safe shores

Parachute Rocket



Applications

A day or night long-range distress signal may be carried on ships bridge and 4 are required to be fitted in ships lifeboats and liferafts.

Design and function

The launching tube has clear instructions and a non-slip surface to ensure safe operation even when launched with one hand. The IKAROS parachute rocket is water proof and can be held under water in the ready to fire position.

General

The IKAROS parachute rocket was introduced in 1959 and the same design is now used by most manufacturers around the world. The IKAROS original is the leading parachute rocket with quality and performance that meets the highest demands on function and safe operation. The IKAROS parachute rocket is approved globally and meets that latest SOLAS 74/96 regulations.



Specifications

Product Code	: P01103
Height of launching	: 350m
Flare inminance	: 30,000 cd
Flare time	: >40s
Storage Temperature	: should not exceed + 75°C
Validity	: 3 years
Dimensions	: 277 X 47mm
Weight	: 345 gm

Directions for use



Remove bottom lid.

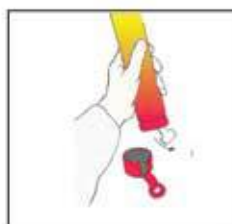

Trigger falls down.

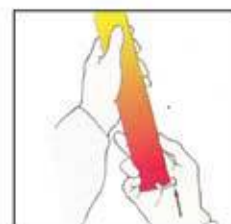

Squeeze trigger against outer casing.



WARNING :

- Keep out of reach of children
- Only for emergency use at sea
- If damaged or dented do not use
- Do not dismantle
- Keep away from source of heat
- Do not use after expiry date



DISPOSAL :

- Pyrotechnics must be treated as hazardous items and must be disposed of responsibly in accordance with local regulations. For help and advice, visit our website www.shmgroup.com



safe seas, safe shores



MARINE DISTRESS SIGNALS

Red Handflare



Applications

A day or night short-range distress signal used to pinpoint position. Maybe carried on ships bridge and six are required to be fitted in ships lifeboats and liferafts.

Design and function

The case is made of corrosion-resistant steel and is designed to withstand exceptional environmental exposure, and to perform reliably even after immersion in water.

General

The IKAROS Red Handflare is designed to give maximum output in a minimum size. It is approved globally and meets the latest SOLAS 74/96 regulations

Specifications

Product Code	: P01104
Luminous Intensity	: 15,000 cd
Flare time	: 60s
Storage Temperature	: should not exceed + 75 °C
Validity	: 3 years
Dimensions	: 243 X 30mm
Weight	: 235 gm

Directions for use

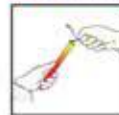

Open the lid.

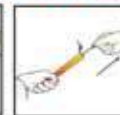

Pull the loop. The flare ignites after 2s delay.

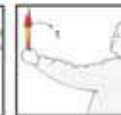

Hold the flare in your hand.



Buoyant Smoke



Applications

For daylight distress signalling purposes on ships, lifeboats and liferafts. It provides effective position marking during rescue operations and can be used to indicate wind direction.

Design and function

The case is made of corrosion-resistant steel and produces a dense smoke for a minimum of 3 minutes.

General

The IKAROS Buoyant Smoke Signal is approved globally and meets the latest SOLAS 74/96 regulations.

Specifications

Product Code	: P01105
Smoke Time	: 3 min
Smoke Colour	: Orange
Storage Temperature	: should not exceed + 75 °C
Dimensions	: 95 X 101 mm
Weight	: 510 gm
Validity	: 3 years

Directions for use



Remove the lid.



Pull the loop.



Throw the signal into the water.



WARNING :

- Keep out of reach of children
- Only for emergency use at sea
- If damaged or dented do not use
- Do not dismantle
- Keep away from source of heat
- Do not use after expiry date

DISPOSAL :

- Pyrotechnics must be treated as hazardous items and must be disposed of responsibly in accordance with local regulations. For help and advice, visit our website www.shmgroup.com





宁波振华公司
Ningbo Zhenhua Co., Ltd.

safe seas, safe shores

Parachute Rocket





Product Code	: P02103
Height of Launching	: 300 m
Flare Imminance	: 30,000 cd
Flare Time	: >40s
Storage Temperature	: -30°C to +65°C
Validity	: 3 years
Dimensions	: 47 X 260mm
Weight	: 345 gm

- 
Remove the top & bottom caps.
- 
Pull out ignition line and pull hard.
- 
Hold signal with both hands. after 2s the rocket will fire.

Red Handflare





Product Code	: P02104
Luminous Intensity	: 15,000 cd
Flare Time	: 60s
Storage Temperature	: -30°C to +65°C
Validity	: 3 years
Dimensions	: 195 X 28mm
Weight	: 235 gm

- 
Turn handle, screw off cap.
- 
Pull ignition cord.
- 
Hold flare leeward.

Buoyant Smoke



Product Code	: P02105
Smoke Time	: 3 min
Smoke Colour	: Orange
Storage Temperature	: -30°C to +65°C
Dimensions	: 95 X 145mm
Weight	: 510 gm
Validity	: 3 years

- 
Open protective cover.
- 
Pull of the cord quickly.
- 
Throw it in to the sea.

Linethrower



Product Code	: P02102
Performance	: Throws a line
Throwing Distance	: >230m in calm water
Lenth of Line	: 4mm X 270m
Line Strength	: 2000N
Storage Temperature	: -30°C to +65°C
Weight	: 4.6 kg
Validity	: 3 years



Man-Overboard Light & Smoke



Product Code	: P02101
Light Luminance	: 2 cd
Lights Burn Time	: 2 hours
Smoke Time	: 15 min
Storage Temperature	: -30°C to +65°C
Dimensions	: 120 x 325mm
Weight	: 4.3 kg
Validity	: 3 years

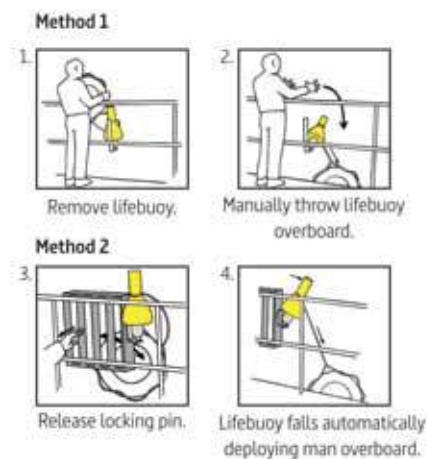

WARNING :

- Keep out of reach of children
- Only for emergency use at sea
- If damaged or dented do not use
- Do not dismantle
- Keep away from source of heat
- Do not use after expiry date



DISPOSAL :

- Pyrotechnics must be treated as hazardous items and must be disposed of responsibly in accordance with local regulations. For help and advice, visit our website www.shmgroupp.com



safe seas, safe shores



SmartFind EPIRB



The **SmartFind** series consists of two models

E5 SmartFind (Code: G01101) is a 406 MHz EPIRB designed to operate with the COSPAS-SARSAT international search and rescue system.

G5 SmartFind PLUS (Code: G01102) has all the advanced features of the standard E5 SmartFind with the addition of an integral multi-channel GPS receiver.

Key Features

- Transmits on 406 and 121.5 MHz
- Integrated GPS (G5 PLUS version)
- Available with a manual bracket or an automatic deployment housing.
- 60 comprehensive diagnostic and self-tests during battery life
- Once activated, will transmit for a minimum of 48 hours
- 6 years battery life & 5 years warranty



EPIRB HRU | Code: G01103

R5 GMDSS VHF Handheld Radio



A fully featured GMDSS survival craft radio built to meet latest stringent IMO, GMDSS and ETSI standards. Drop tested to cope with the toughest marine environments.

The large tactile buttons can easily be operated with gloves. A ribbed design ensures a solid grip even in wet conditions.

Key Features

- 23 GMDSS channels
- Waterproof to 1/2m for 1/2 hour
- Dimming and backlight control
- Battery indicator and battery saving
- Quick channel select button
- Keypad lock
- Rotary volume control
- Dual-/Tri watch
- Battery storage and charger base options

Pack A - Full featured option | Code: G02101

R5 VHF Body + Single charger kit

- Lithium Battery-Primary, Belt clip, Lanyard, Test report, Manual, Antenna whip, Storage base
- Li-ion rechargeable battery, Single Charger base, AC/DC converter, DC connector cables, AC/DC converter instruction sheet

Pack B - Survival craft option | Code: G02102

R5 VHF Body

- Lithium Battery-Primary, Belt clip, Lanyard, Test report, Manual, Antenna whip, Storage base

S4 Rescue Radar SART



The S4 Rescue Radar SART is a 9GHz X-band Search and Rescue Locating Device which offers proven reliability.

When a radar signal is received from a ship or aircraft, the S4 Rescue automatically transmits a response signal, which clearly identifies the survival craft on the radar screen by means of a stream of 12 in-line dots.

Once activated, the S4 will remain in standby mode for over 96 hours.

Key Features | Code: G03101

- | | |
|-------------------------------------|--|
| ▪ Ship or survival craft options | ▪ Audio/visual indication of operation |
| ▪ Waterproof to 10m | ▪ Built-in test facility |
| ▪ Buoyant | ▪ Integral lanyard |
| ▪ Compact and lightweight | ▪ Mounting options - internal / external |
| ▪ Replaceable, 5 years battery pack | |

SmartFind S5 AIS SART



The SmartFind S5 AIS, Search and Rescue locating device is a portable device packed inside a quick release carry off bag for quick evacuation.

SmartFind S5 AIS SART transmits target survivor information including structured alert messages, GPS position information and serialised identity number.

Once activated the S5 AIS SART transmits continually for a minimum of 96 hours.

An inbuilt high precision GPS provides accurate position information to assist in quick location of survival craft.

Key Features | Code: G03102

- Ship or survival craft options
- Waterproof to 10m
- Buoyant/floats
- 6 years battery life (Non-hazardous)
- Visual indication of operation
- Built-in test facility, Integral lanyard
- Mounting options-internal/external



SmartFind GMDSS NAVTEX Receiver



The SMARTFIND Global Maritime Distress and safety System (GMDSS) NAVTEX provides clear and up-to-date NAVTEX maritime safety and weather information.

Three parallel digital receivers simultaneously provide tri-channel monitoring of the international 518 Khz English language service, 490 Khz national language and the 4209.5 Khz long range NAVTEX services.

It can either be operated as a stand-alone unit or as part of an integrated navigation or bridge system.

Key Features | Code: G05101

- Large 6" colour display
- Simple and intuitive to use
- Easy to read extra large font
- Tri-channel simultaneous reception
- ESM® Enhanced Signal Monitoring
- Printer output
- GPS interface capability
- INS and ECDIS interface capability
- Range of antennas available

SmartFind M5 AIS Class A Transponder



SmartFind M5 Class A provides automated AIS communication from 'ship-to-ship' and 'ship-to-shore', transmitting and receiving vessel, voyage and safety related information.

Key Features | Code: G04101

- Compact design
- 3.5" colour LCD display
- Embedded coasting map
- Detailed target list and radar overview
- GPS antenna
- Features AIS MOB SART alarm to aid MOB recovery
- Cable junction box, Pilot plug
- Mounting kit and flush mount
- PC AIS Viewer software

Items Included

- Transponder unit with colour display
- GPS antenna
- Junction box and link cable
- Pilot plug - remote socket box
- Companion PC AIS Viewer Software



safe seas, safe shores

SmartFind M10 AIS Class B Transponder | M15 AIS Receiver



Code: G04102

Code: G04103

SmartFind S10 AIS MOB Device



Code: G04104

Ideally suited where the complexity of an AIS Class A Transponder is not necessary, the McMurdo SmartFind M10 AIS Class B Transponder and SmartFind M15 AIS receiver range will receive and process all AIS targets within 20 miles of the vessel, typical.

The SmartFind S10 AIS MOB Device is an innovative manually activated personal safety device which incorporates both AIS (Automatic Identification System) and GPS technology.

It is designed to aid the speedy recovery of personnel/crew members who find themselves in difficulty at sea.

SmartFind M10

AIS Class B Transponder

- GPS, In built data logger
- NMEA 2000 & NMEA 0183
- USB
- 12/24v DC
- WiFi (M10W version)

SmartFind M15

AIS Receiver

- Dual channel
- NMEA 0183
- USB 2.0
- 12/24v DC
- Splitter (M10S version)

SmartFind 220 Personal Locator



Code: G06102

Using the dedicated 406MHz frequency, FastFind 220 transmits your unique ID and precise GPS location to the global network of search and rescue satellites. Designed for marine enthusiasts and adventurers; buoyancy pouch included.

SmartFind S20 AIS MOB Device



Code: G04105

The SmartFind S20 has been designed as a personal AIS search and rescue locating device, which transmits target survivor information, including GPS information and a serialized identity number.

FastFind MaxG Personal Locator



Code: G06101

The FastFind MaxG's integral state-of-the-art-multi-channel GPS receiver gives search and rescue services your precise co-ordinates with regular updates.

McMurdo equipment is available ex-stock through SHM's distribution network



safe seas, safe shores

Hydrostatic Release Unit



Product Code: S05101
The Hammar H20 is designed to activate release at depths of between 1.5-4m

Ration - Seven Oceans



Product Code: S05103
Emergency food ration 500gms with 5 years shelf life

Water - Seven Oceans



Product Code: S05104
Emergency drinking water 500ml with 5 years shelf life

Retro Reflective Tape



Product Code: S04120
Retro Reflective tape 2" X 50 Mtrs rolls in accordance to SOLAS (LSA) code

Hatchet



Product Code: S04108
Short handled, single edge hatchet for use in lifeboats

FRP Repair Kit



Product Code: S04106
Fiberglass Repair Kit for lifeboats and rescue boats

Heliograph Mirror



Product Code: S04109
A compact daylight signalling mirror

Radar Reflector



Product Code: S04117
Made of special lightweight alloy treated against corrosion, folds flat for storage

Fishing Kit



Product Code: S04105
Survival fishing kit



safe seas, safe shores

Bailer



Product Code: S04101
Plastic bailer used to remove accumulated sea water

Manual Bilge Pump



Product Code: S05106
Portable pump for easily removing bilge water

Buoyant Heaving Line



Product Code: S04102
Orange Polypropylene floating line of 30m in length

Crutches



Product Code: S04103
Galvanised crutches to hold boat oars

Dipper with Chain



Product Code: S04104
Rustproof dipper with chain

Graduated Drinking Vessel



Product Code: S04107
Rustproof graduated drinking vessel

Jack Knife



Product Code: S04110
Knife with lanyard for use in lifeboats and liferafts

Survival Matches



Product Code: S04112
Windproof matches packed in sealed waterproof container

Floating Knife



Product Code: S04113
Buoyant floating knife with Rounded blade



safe seas, safe shores

Rescue Quoit & Line

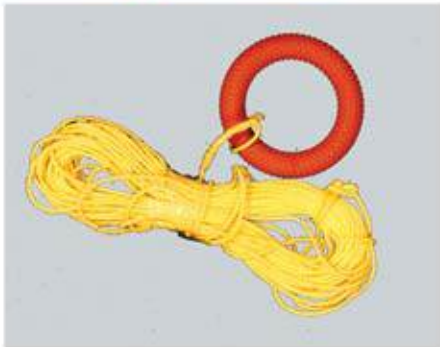

Product Code: S04118
Quoit complete with 30m self floating rope, deployable for immediate rescue

Oars - Lifeboat & Liferaft



Product Code: S04114
Light weight and durable oars. Available in plastic or wood

Sea Anchor



Product Code: S04121
Used to slow down boat or liferaft when facing strong winds or heavy seas

Day Signal Shapes

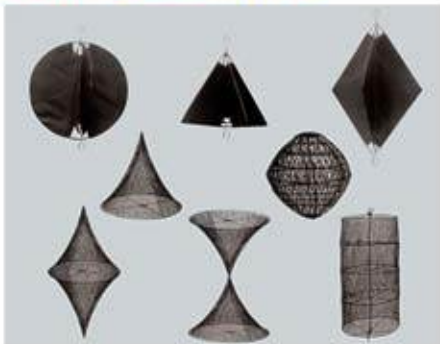

Product Code: S04126
Ball, cylindrical, conical, double conical and diamond shape

Signalling Flags



Product Code: S04127
International marine signal flags

Signalling Torch



Product Code: S04123
Waterproof rubber signalling torch with lanyard and batteries

Oil Bag



Product Code: S04115
Canvas bag loosely filled with oil absorbent material (Oakum)

Senhouse Slip



Product Code: S04122
Fits between HRU and lashing strap, securing a liferaft in its cradle

Search Light



Product Code: S05107
Watertight, hand-held search light with morse and on/off switch



safe seas, safe shores

Rescue Signaling Card

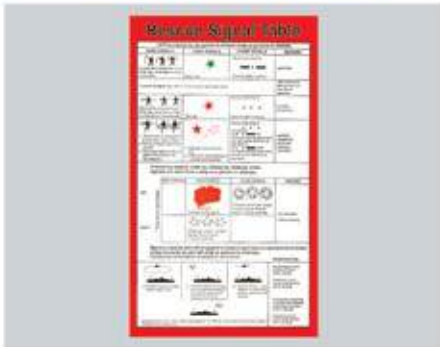

Product Code: S04119
International search and rescue communication signals waterproof card

Survival Manual



Product Code: S04124
Waterproof survival instruction manual for liferafts and lifeboats

Painter Line



Product Code: S04116
Heavy duty polypropylene braided line that floats on the water

Whistle



Product Code: S04125
Whistle with lanyard

Anti - Seasickness Tablets



Product Code: S05102
Anti sea sickness Tablets for liferafts and lifeboats

Anti - Seasickness Bag



Product Code: S04129
Plastic sea sickness bag for liferafts and lifeboats

Boat Hook



Product Code: S04111
For docking and rescuing a person. Wood or plastic extendable pole available

First Aid Kit



Product Code: S05108
First Aid Kit SOLAS. Available in a plastic container or metal foil pouch

Lifeboat FPD



Product Code: S04128
Used during maintenance for avoiding accidents. Maximum break level of 40 T



safe seas, safe shores

IMO Signs & Posters



Material

- Self Adhesive Vinyl
- Rigid or Milky White Plastic
- Rigid PVC
- Aluminium
- Self Adhesive Paper
- Stainless Steel

As per the IMO, all commercial vessels must have a certain number of mandatory, hazard, safety, fire, direction, and prohibitory signs. These signs are colour coded as per their description, and are either lit by emergency lighting or are photoluminescent for at least an hour once the light source has been cut off.



SHM's Signs and Posters conform to all regulations and requirements of the IMO. They are manufactured in high photoluminescent quality, and the raw materials and finished products are regularly tested by national accredited laboratories.

Categories

- Safety Signs
- Direction Signs
- Fire Control Signs
- Hazard Signs
- Fire Equipment Signs
- Mandatory Signs
- Prohibitory Signs
- Combination Signs
- ISPS Code Signs
- Deck & Engine Room Signs
- Gallery & Accommodation Signs
- Temporary Hazard & Identification
- Marker Dots & Tapes
- Safety Awareness & Training
- Do's & Don't's Safety Awareness
- Safety First Posters
- Hazard Diamonds
- Nylon Seals & Fire Plan Holder

IMO Signs can be supplied within 24 HOURS across SHM's distribution network



safe seas, safe shores

Safety Signs



Direction Signs



Fire Control Signs

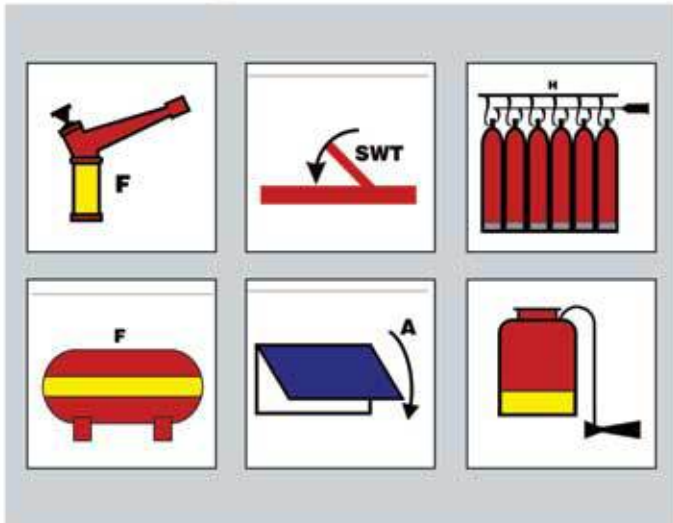

Hazard Signs



Fire Equipment Signs



Mandatory Signs





safe seas, safe shores

Prohibitory Signs



Combination Signs



ISPS Code Signs



Deck & Engine Room Signs



Galley & Accommodation Signs



Temporary Hazard & Identification Tags





safe seas, safe shores

Marker Dots & Tapes

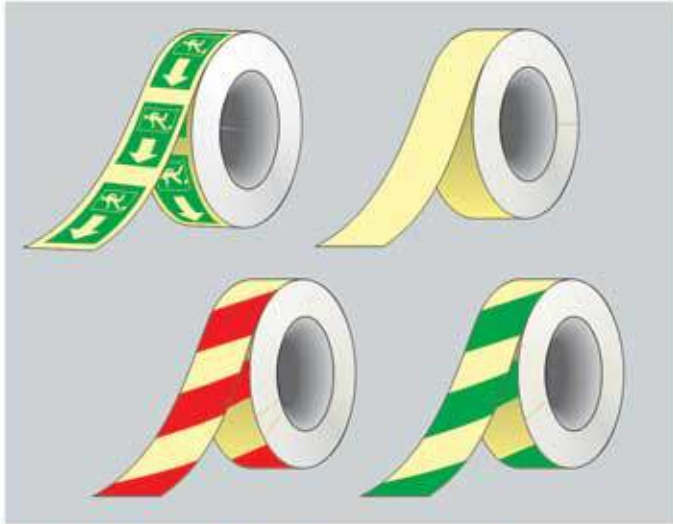

Safety Awareness & Training Posters



Do's & Don'ts Safety Awareness Posters



Safety First Posters



Hazard Diamonds



Nylon Seals & Fire Plan Holder





safe seas, safe shores

Personnel Transfer Net X-904

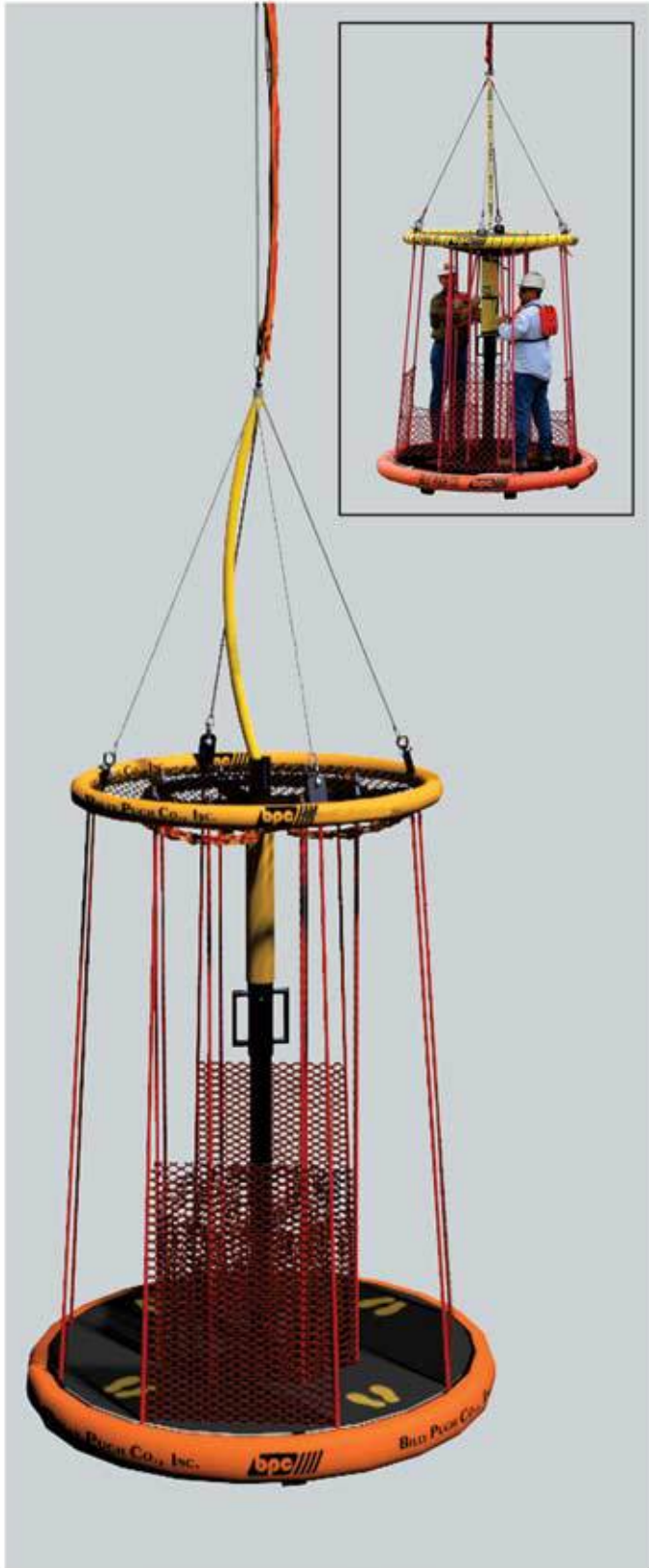

The X-904 is the safest and most advanced transfer device on the market today. Three important features set the X-904 apart: man positioning, overhead protection, and side impact protection.

The X-904's unique Man Positioning System provides the rider a sense of security while still affording the ability to immediately depart from the device. As riders board the X-904, they fasten a quick release lanyard to their work vest. The lanyard stabilizes the rider in position should he become dizzy or disoriented during the transfer.

The expanded metal top is incorporated in the design to protect the rider from falling objects and riders are on the inside of the device where they are protected by rope encapsulated stainless steel cables which form the outer rigging of the X-904.

Key Features:



- **Capacity:** 4, 6, 8, 10, and 12 persons available
- **Certification:** ABS
- **Storage:** Collapsible
- **Floor:** Shock absorbing and non-slip
- **Frame:** Lightweight aluminium
- **Rope:** Double braid polydacron coated with urethane with stainless wire rope center
- **Accessories:** 20ft. stabilizer and load line included
- **Stretcher space:** Yes
- **Overhead protection:** Yes

Tag Line



Code: T01116

Storage Cover



Code: T01111

Carabiner for Tag Line



Code: T01117

Stabilizer



Code: T01118

Product Code: T01101



safe seas, safe shores

Personnel Transfer Net X-871



Product Code: T01106

The Billy Pugh Personnel Basket X-871 has been the symbol of the offshore oil and gas industry for over 50 years. It has set the standard for safety and efficiency in crane transfers.

It is still a very popular and effective device for offshore transfer of personnel and it's commonly used in almost every major marine oil and gas market in the world.

Key Features:



- **Capacity:** 4, 6, 8, 10, and 12 persons available
- **Certification:** ABS
- **Storage:** Collapsible
- **Floor:** Shock absorbing and non-slip
- **Frame:** Lightweight aluminium
- **Rope:** Double braid polydacron coated with urethane with stainless wire rope center
- **Accessories:** 20ft. stabilizer and load line included
- **Stretcher space:** Yes
- **Overhead protection:** Yes

Swing Rope



Product Code: T01119

The standard Billy Pugh Swing Rope is a 3/4" polydacron rope with 5 knots, spaced 2 feet apart. The rope is dipped in liquid polyurethane.

It is prepared with a stainless steel thimble and eye splice on one end and all swing ropes can accommodate a carabiner. Customized sizes are available upon request.

Work Vest

USCG Approved



Billy Pugh's Work Vests are USCG Type V approved. These work vests are made of vinyl coated, unicellular plastic foam, and are constructed for chest sizes 90-125 cm. Available in two basic models:

WVO-50 | Code: L10101

WVO-100 | Code: L10102

- Straps inside the foam
- Straps outside the foam
- Body harness version also available (WVO-50S)

Billy Pugh products are available as per your requirements through SHM's global distribution network



safe seas, safe shores

Helicopter Crash Kit

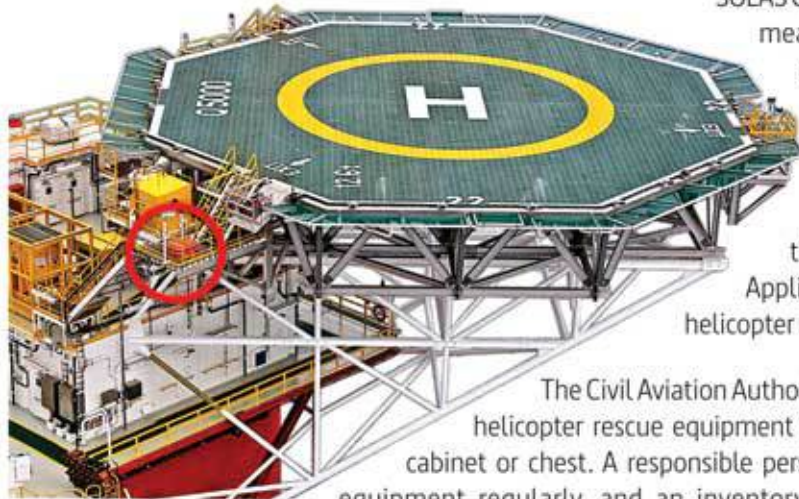

SOLAS Chapter II-2, Part G, Regulation 18 states that additional measures should be taken to address the fire safety objectives of this chapter for ships fitted with special facilities for helicopters.

Therefore, the following fire fighting appliances shall be provided and stored near the means of access to the helideck in close proximity: Fire Extinguishers, Foam Application System, 2 sets of Fire-Fighter's Outfits, and a set helicopter rescue equipment.

The Civil Aviation Authority's (CAA UK) CAP 437 standards strongly recommend helicopter rescue equipment be stored in a clearly marked and secure watertight cabinet or chest. A responsible person should be appointed to check and maintain the equipment regularly, and an inventory checklist should be held inside the equipment cabinet/chest. We can also tailor make the crash kit to meet local regulatory and client requirements.

CAP437 & SOLAS Recommendations

Item	H1/H2	H3
Adjustable Wrench	1	1
Rescue Axe, Large	1	1
Bolt Cutters	1	1
Crowbar, Large	1	1
Hook, Grab or Salving	1	1
Hacksaw (Heavy duty) w 6 spare blade	6	6
Blanket, Fire Resistant	1	1
Ladder (2 piece)*	1	1
Fire Proof Lifeline	1	1
Pliers, side cutting (tin snips)	1	1
Assorted screwdrivers	1	1
Harness knife and sheath**	1	1
Gloves , Fire Resistant**	1	1
Fire-Fighter's Outfit	2	2
Power cutting tool	-	1

* For access to casualties in an aircraft on its side

** This equipment is required for each helideck crew member

H1: A helicopter with an overall length up to but not including 15m

H2: A helicopter with an overall length from 15m upto but not including 24m

H3: A helicopter with an overall length from 24m upto but not including 35m

Helicopter Crash Kit, Cabinet Version



Product Code: M06101

Dimensions: 1530 (H) x 910 (W) x 495 (D)

Helicopter Crash Kit, Chest Version



Product Code: M06102

Dimensions: 605 (H) x 935 (W) x 480 (D)



safe seas, safe shores

Personnel Transfer Net X-871



Product Code: T01106

The Billy Pugh Personnel Basket X-871 has been the symbol of the offshore oil and gas industry for over 50 years. It has set the standard for safety and efficiency in crane transfers.

It is still a very popular and effective device for offshore transfer of personnel and it's commonly used in almost every major marine oil and gas market in the world.

Key Features:



- **Capacity:** 4, 6, 8, 10, and 12 persons available
- **Certification:** ABS
- **Storage:** Collapsible
- **Floor:** Shock absorbing and non-slip
- **Frame:** Lightweight aluminium
- **Rope:** Double braid polydacron coated with urethane with stainless wire rope center
- **Accessories:** 20ft. stabilizer and load line included
- **Stretcher space:** Yes
- **Overhead protection:** Yes

Swing Rope



Product Code: T01119

The standard Billy Pugh Swing Rope is a 3/4" polydacron rope with 5 knots, spaced 2 feet apart. The rope is dipped in liquid polyurethane.

It is prepared with a stainless steel thimble and eye splice on one end and all swing ropes can accommodate a carabiner. Customized sizes are available upon request.

Work Vest

USCG Approved



Billy Pugh's Work Vests are USCG Type V approved. These work vests are made of vinyl coated, unicellular plastic foam, and are constructed for chest sizes 90-125 cm. Available in two basic models:

WVO-50 | Code: L10101

WVO-100 | Code: L10102

- Straps inside the foam
- Straps outside the foam
- Body harness version also available (WVO-50S)

Billy Pugh products are available as per your requirements through SHM's global distribution network



safe seas, safe shores

Dura Fibreglass Cabinets

SHM's range of Dura cabinets offer tough, cost-effective, and long-lasting portable storage solutions for your life-saving and fire safety equipment. The high quality fibreglass construction and durable corrosion resistant Italian fittings are ideal for use in offshore and onshore environments. They can be further customized to be wall mounted and can incorporate a polycarbonate window for easy inspection. All cabinet specifications can be changed to meet your requirement.

Dura 101



The Dura 101 cabinet provides an ideal storage space for a single Fire Extinguisher.

Specifications

- Product Code : D01101
- IP Rating : IP 56
- Dimensions : H970 x W470 x D320
- Aperture : H830 x W317
- Colour : Red, Green, or as required
- Material : GRP 3-4mm Thickness
- Fittings : SS 316, Plastic Ball Catch, EPDM Seal

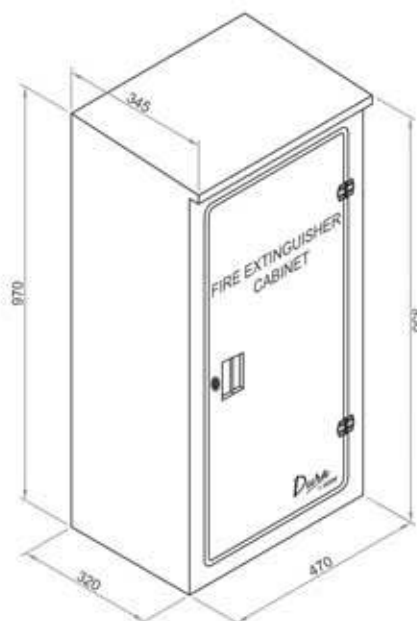

Dura 102



The Dura 102 cabinet can be used to store two fire extinguishers or two fire hose or other compact equipment such as EEBDs (5 Nos.), Descent Devices (12 Nos), etc.

Specifications

- Product Code : D01102
- IP Rating : IP 56
- Dimensions : H950 x W820 x D325
- Aperture : H750 x W633
- Colour : Red, Green, or as required
- Material : GRP 3-4mm Thickness
- Fittings : SS 316, Plastic Ball Catch, EPDM Seal

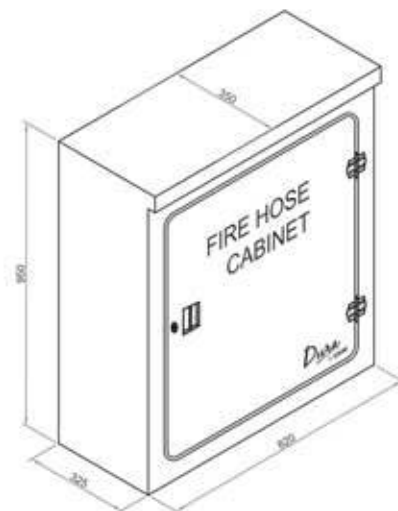



safe seas, safe shores

Dura 103



The Dura 103 cabinet is the most versatile storage option in our range. It can be used to store two fireman's equipment / multiple fire hoses / four breathing apparatus / 20 inflatable lifejackets / eight solid lifejackets / a complete helicopter crash kit.

Specifications

- Product Code : D01103
- IP Rating : IP 56
- Dimensions : H1600 x W914 x D756
- Aperture : H1222 x W659
- Colour : Red, Green, or as required
- Material : GRP 3-4mm Thickness
- Fittings : SS 316, Plastic Ball Catch, EPDM Seal

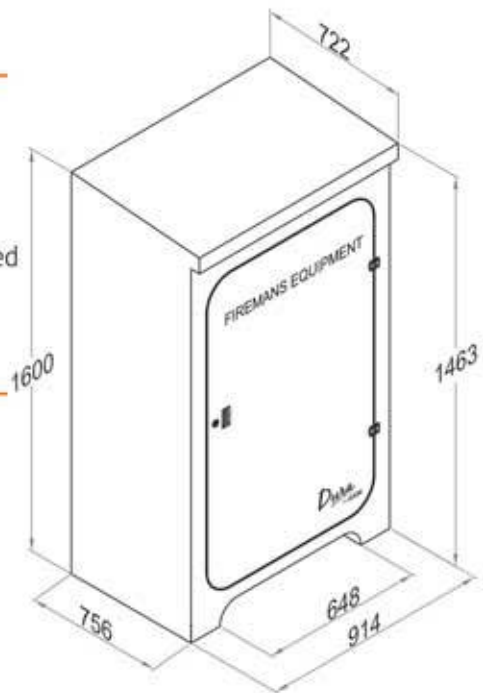

DURA FIBREGLASS CABINETS

Dura 104



The Dura 104 cabinet is a smaller version of the Dura 3. It can be used to store one fireman's equipment / four fire hoses / 12 inflatable lifejackets / about 30 nos descent devices.

Specifications

- Product Code: D01104
- IP Rating : IP 56
- Dimensions : H1453 x W830 x D516
- Aperture : H1110 x W598
- Colour : Red, Green, or as required
- Material : GRP 3-4mm Thickness
- Fittings : SS 316, Plastic Ball Catch, EPDM Seal

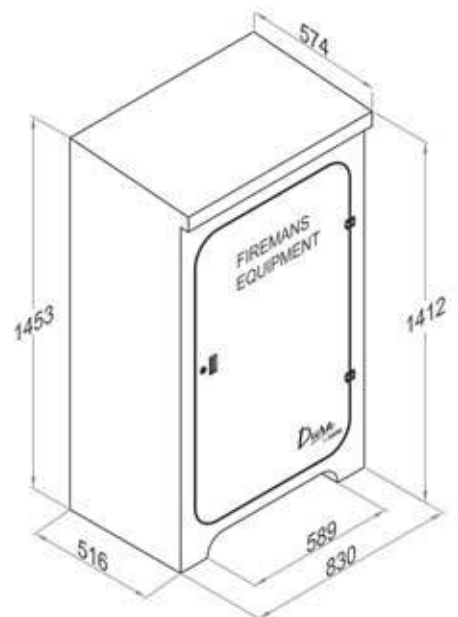



safe seas, safe shores

Dura
by SHM

DURA FIBREGLASS CABINETS

Dura 105

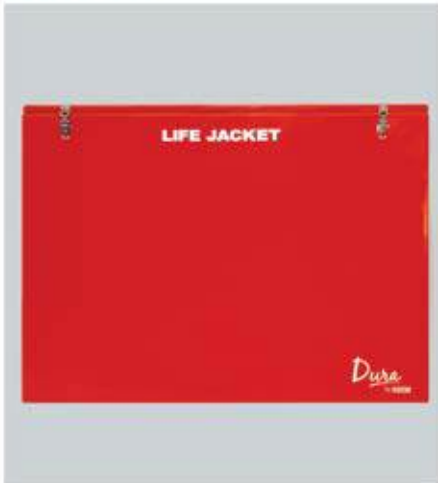

The Dura 105 is a great option for seekers of horizontal storage solutions. It is ideal to store 6 immersion suits or 15 solid lifejackets apart from other safety equipment.

Specifications

Product Code : D01105
IP Rating : IP 56
Dimensions : H880 x W1160 x D755
Aperture : W1100 x D625
Colour : Red, Green, or as required
Material : GRP 3-4mm Thickness
Fittings : SS 316, Plastic Ball Catch, EPDM Seal

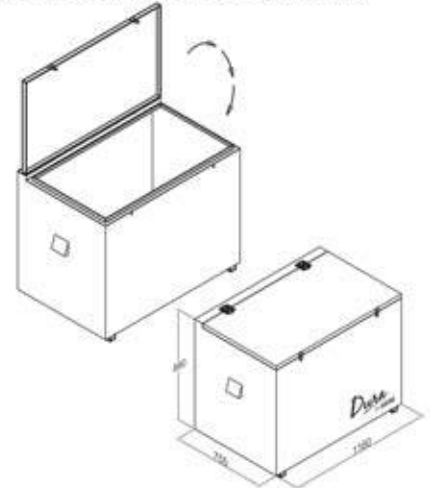

Dura 106



The Dura 106 is more catered towards storage of medical equipment on board. It fits a complete Paraguard Excel Stretcher or can also be used for storing four fire hoses.

Specifications

Product Code : D01106
IP Rating : IP 56
Dimensions : H1310 x W635 x D460
Aperture : H1121 x W450
Colour : Red, Green, or as required
Material : GRP 3-4mm Thickness
Fittings : SS 316, Plastic Ball Catch, EPDM Seal

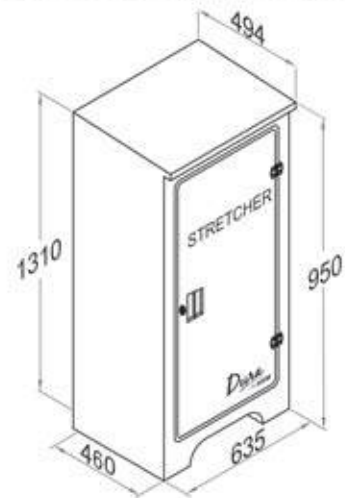

Dura 107

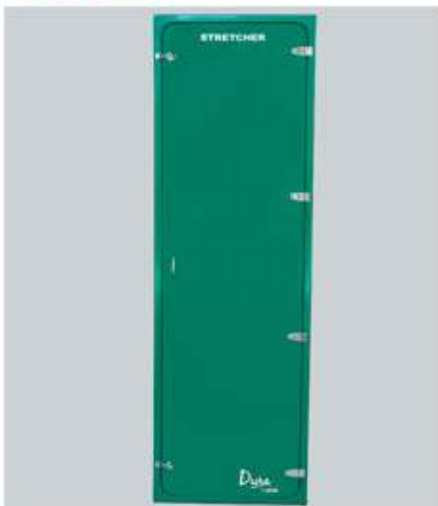

The Dura 107 is the tallest in our range and is specially crafted for storing all universal basket stretchers

Specifications

Product Code : D01107
IP Rating : IP 56
Dimensions : H2340 x W770 x D285
Aperture : H2183 x W610
Colour : Red, Green, or as required
Material : GRP 3-4mm Thickness
Fittings : SS 316, Plastic Ball Catch, EPDM Seal





safe seas, safe shores

Dura
by SHM

DURA FIBREGLASS CABINETS

Dura 108



The Dura 108 cabinet can be used for storage of Helicopter Crash Kit Equipment.

Specifications

Product Code : D01108
 IP Rating : IP 56
 Dimensions : H620 x W940 x D490
 Aperture : W898 x D398
 Colour : Red, Green, or as required
 Material : GRP 3-4mm Thickness
 Fittings : SS 316, Plastic Ball Catch, EPDM Seal

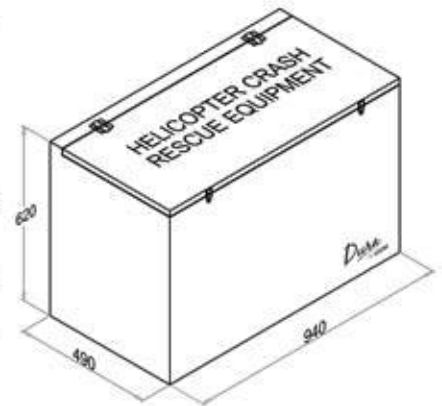

Dura 109



The Dura 109 cabinet is ideal for storage of long wooden handled Fireman's Axe

Specifications

Product Code : D01109
 IP Rating : IP 56
 Dimensions : H1100 x W460 x D350
 Aperture : H941 x W323
 Colour : Red, or as per requirement
 Material : GRP 3-4mm Thickness
 Fittings : SS 316, Plastic Ball Catch, EPDM Seal

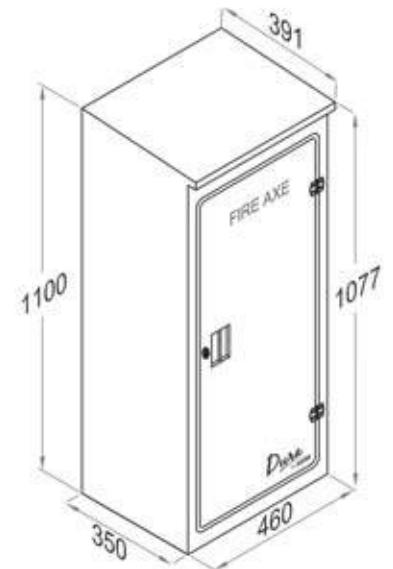

Accessories

SS 316 Latch



Code : D02101

EPDM Seal



Code : D02102

SS 316 Hinge



Code : D02103

Plastic Ball Catch



Code : D02104



safe seas, safe shores



TRANSFER & DESCENT EQUIPMENT

Donut Personal Controlled Descent Device | Code : T02101



Patented design, light-weight for tertiary means of escape

The patented Donut is a simple, lightweight device designed as a tertiary means of escape at sea and on land. Units have been deployed in the field for over 22 years from the extreme heat conditions of the Middle East, Far East and Australia to the extreme cold of Canada and Russia.



- 1 Harness
- 2 Containment Bag
- 3 Descender Unit
- 4 High Strength Tape
- 5 Wire Strop
- 6 Liferaft Strop
- 7 Quick Release Mechanism

The Donut has international regulatory approval, including:



Product Highlights

The Donut enables personnel to escape by means of Individual Controlled Descent once the device has been attached to a handrail or other load bearing structure. It can be used for:

- **Guided Escape to a Liferaft**
The Donut has been designed to assist an evacuation to a liferaft by incorporating a strop, which is attached to the liferaft painter line. The painter line acts as a guide, during descent, for entry into the liferaft.
- **Escape From Drill Derricks & Cranes**
Donut provides a means of evacuation from areas of entrapment such as cranes and derricks. The unit can be stored in these areas for use, or hand carried to the workplace as required.
- **Injured Party Rescue**
The Donut can be simply adapted to enable the evacuation of an injured person either seated in the harness or fixed to a stretcher. The injured person can then be lowered in a controlled manner.

Recertification

The Donut device, within an Approved Recertification Scheme, needs to be inspected only once in a five year period. In order to maintain safety requirements during recertification, hire units are available at cost effective rates.



safe seas, safe shores

Ladders

Pilot Ladder | Code : T03101

Pilot ladders remain the most safe and efficient way to board ships at sea. Nevertheless, a number of pilots have died/been injured due to defects in the ladder treads, side ropes or a lack of proper attachment of the ladder to the vessel. As per IMO, Shipping companies have a legal obligation to ensure that their ladders are SOLAS compliant, replacement ladders are readily available on board, and their seafarers receive necessary training.

Embarkation Ladder | Code : T03102

The SOLAS convention requires ladders at survival craft embarkation stations to provide a safe means of climbing down the ship's side when a vessel is at an excessive heel angle or abandoning when at sea in adverse conditions.

We can manufacture our ladders to meet your specific length and material requirements. Our ladders are available in hardwood, polymer, and aluminium.



TRANSFER & DESCENT EQUIPMENT

Pilot Ladder Magnets for Safe Pilot Transfer



Accessories :

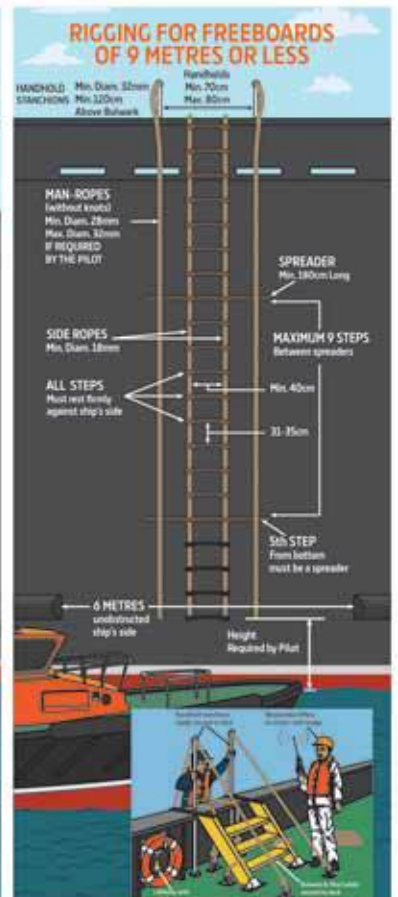
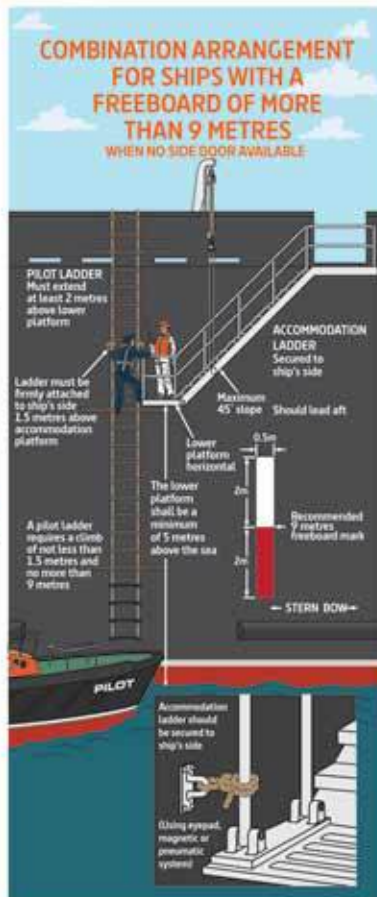



safe seas, safe shores

All kinds of Nets

We can make all kinds of nets in various sizes, tailor made to your specifications. The most commonly used materials include Polypropylene, Nylon, Manila, etc.



Cargo Net | Code : T04101

A cargo net, usually square or rectangle, is used in transferring cargo to and from ships.



Scramble Net | Code : T04102

A Scramble net is fixed to the rail or deck for quick deployment, and for easy rolled up storage. In the event of an emergency, the scramble net allows a large number of crew and passengers to disembark. They usually come with spreader bars made of wood, fibreglass, aluminium etc.

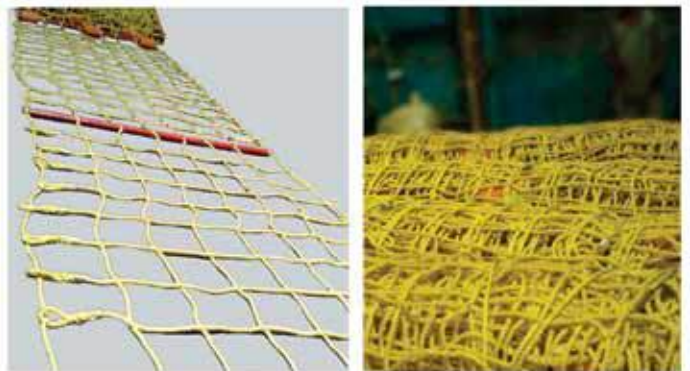

Gangway Safety Net | Code : T04103

The Gangway and Accommodation Ladder safety netting must be fitted under every part of the ladder, extending on both sides, and must be kept taut at all times.



Helipad / Helideck Net Code : T04104

Helideck Nets are used on the offshore helicopter landing decks, oil rigs and platforms where more friction and support is required. The purpose of these nets is to prevent the Helicopter from rolling and pitching off the helipads.





safe seas, safe shores

Jason's Cradle Man Overboard Solutions

The Jason's Cradle® MOB system are fully SOLAS approved, most respected MOB recovery, embarkation/disembarkation and evacuation system in the world. Jason's Cradle® is designed to retrieve people quickly and horizontally from the water, thus reducing the possibilities of "dry drowning" now more commonly known as Circum Rescue Collapse. We can offer the below four types of Jason's Cradle® products to suit your specific requirements.

Standard Unit | Code : T05101

The FRC Kit is suitable for all Fast Rescue Craft. It consists of a Jason's Cradle with stowage bag and a fixing kit that enables the cradle to be deployed on both port and starboard sides

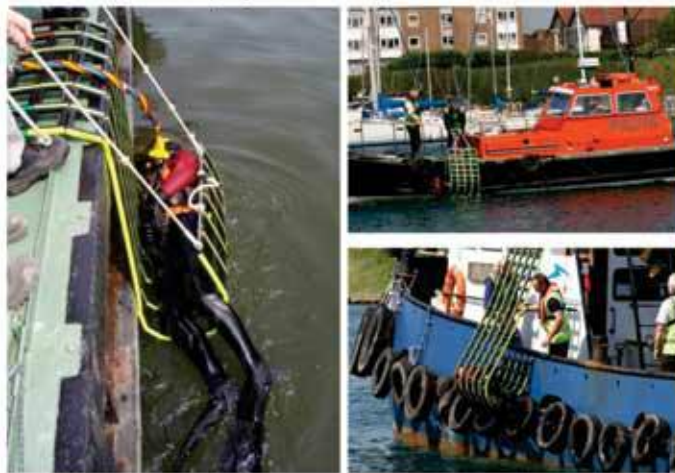

FRC Kit | Code : T05102

The Standard unit is suitable for most vessels with up to 4.5m freeboard. It's simply fixed to the deck or rail to enable deployment within seconds



Scramble Net | Code : T05103

The Scramble net is suitable for high sided vessels, rescue zones and mass recovery/evacuation. Large numbers of passengers and crew may simultaneously disembark in the event of an emergency



Stretcher Unit | Code : T05104

The Stretcher unit is most universally accepted method of rescuing a casualty from water. The horizontal recovery position assists in enabling the casualty's blood to remain in the upper torso, minimizing fatal effects of Circum Rescue Collapse.



Jason's Cradle products are available ex-stock across SHM's distribution network



safe seas, safe shores

Marine Chemicals & Test Kits



Vecom Marine
clean ships - clean seas

MARINE CHEMICALS & TEST KITS

The Vecom group was founded in 1953. A family owned company, Vecom offers their customers a great variety of products and services in cleaning & maintenance of metal surfaces.

Vecom manufactures Treatment, Maintenance & Cleaning Products in Maassluis (The Netherlands) and Dietzenbach (Germany). These products are used in both the Industrial and Marine markets and are distributed by Vecom and their distribution partners worldwide.

In India, the SHM Group is proud to provide you with the quality of Vecom products, which have been specified for India's environment and working conditions. If you have any questions please talk to us about our full range of products and we will be happy to discuss how we can continue to be a value adding supplier to your business.



Water Treatment Chemicals

<p>BOILER TREAT ONE SHOT</p> <p>Combined Boiler Water Conditioner Code : 56284 (25 ltr Can)</p> <p>A one-product treatment for all auxiliary boilers including waste heat, and exhaust gas boilers. It prevents scale formation, inhibits corrosion and conditions sludge.</p>	<p>HARDNESS CONTROL</p> <p>Boiler Water Conditioner Code : 56298 (25 ltr Can)</p> <p>Added to the boiler water to maintain optimum phosphate level, which prevents calcium and magnesium hardness salts formation. The precipitate can be removed by blow-down.</p>	<p>ALKALINITY CONTROL</p> <p>Boiler Water Conditioner Code : 56195 (25 ltr Can)</p> <p>Added to the boiler water to maintain optimum alkalinity level to prevent corrosion. Due to this, Ca and Mg hardness salts cannot form and the precipitate is removed by blow-down.</p>
<p>HYDRAZIDE</p> <p>Oxygen Scavenger Code : 56800 (25 ltr Can)</p> <p>Used for rapid removal of oxygen in boiler feed water and condensate systems, which prevents corrosion. It is the alternative for hazardous and potentially carcinogenic products.</p>	<p>BOILER TREAT COMBI</p> <p>Organic Boiler Water Treatment Code : 56279 (25 ltr Can)</p> <p>Special blended low molecular weight compounds that elevate boiler water pH to levels, which reduce corrosion. It also prevents under deposit corrosion caused by excess alkalinity.</p>	<p>LIQUID COAGULANT</p> <p>Oil and Sludge Conditioner Code : 55252 (25 ltr Can)</p> <p>Used to prevent formation of adherent deposits and sticky sludge in boilers, which are then removed by normal blow-down. It can also be used in the event of an oil contamination.</p>
<p>CONDENSATE CONTROL</p> <p>Steam and Condensate Conditioner Code : 56296 (25 ltr Can)</p> <p>Injected into the condensate pump to prevent corrosion in steam and condensate lines. It's also used to protect idle boilers from corrosion. It neutralizes acidic conditions in condensate systems and volatilizes with steam.</p>	<p>COOL TREAT NCLT</p> <p>Corrosion and Scale Inhibitor Code : 56093 (25 ltr Can)</p> <p>Provides an effective anodic inhibitor treatment and protects ferrous and non-ferrous metals. It deposits a microscopic protective film on surfaces and has built-in pH buffering compounds. It controls formation of hard scale deposits.</p>	<p>EVAPORATOR TREAT</p> <p>Prevention of scale in Evaporators Code : 56150 (25 ltr Can)</p> <p>Used in both high and low pressure evaporators to prevent foaming, carry-over and scale formation. It's safe to use where distillate is used for drinking purposes. It prevents scale formation and avoids the need for acid descaling.</p>

Fuel Oil Treatment Chemicals

<p>FOT SLUDGE DISPERSANT</p> <p>Combustion Improver Code : 56222 (25 ltr Drum)</p> <p>Used in both steam and motor vessels burning heavy fuel oils. The treatment disperses sludge, separates water and improves atomization and combustion. It reduces ash deposits and soot emissions, and minimizes corrosion.</p>	<p>BACTERIA CONTROL</p> <p>Microbiological Control Agent Code : 56418 (25 ltr Can)</p> <p>Used in oil storage facilities which have problems due to bacteria colonization and / or algae in the oil / water interface. It's special surface active component ensures complete coverage over large areas.</p>	<p>FOT LI 4100</p> <p>Lubricity Improver Code : 56084 (25 ltr Drum)</p> <p>A non-metallic, phosphorus free lubricity improver, extremely effective at protecting rotary fuel injection equipment from wear when operating with fuels of low intrinsic lubricity. It offers very good solubility and therefore does not negatively affect filterability.</p>
<p>FOT COMBUSTION CATALYST</p> <p>Concentrated Combustion Catalyst Code : 56083 (25 ltr Drum)</p> <p>A combustion improver, carbon catalyst, ash modifier and smoke suppressant for diesel engines burning heavy fuel oils and boilers. It reduces carbon buildup in combustion zones and inhibits formation of carbonaceous ash deposits and sludge formation.</p>	<p>SOOT REMOVER LIQUID / STICKS</p> <p>In Liquid, Powder, or Sticks form Code : 56667 (25 ltr Can) Code : 37020 (20 kg Bucket)</p> <p>Removes unburned carbon slag deposits from boiler furnaces, economizers, air heaters, etc. It reduces cold end corrosion and improves heat transfer due to reduction in deposits. It increases boiler efficiency, reduces cleaning costs.</p>	<p>VALVE TREAT</p> <p>Ash Modifier & Corrosion Inhibitor Code : 56250 (25 ltr Drum)</p> <p>Used both in steam and motor vessels burning heavy fuel oils to improve combustion efficiency, reduce corrosion, disperse sludge and separate water. It is primarily formulated for use in diesel engines to prevent valves failure.</p>

Test Kits

<p>CHLORIDE TEST KIT</p> <p>Chloride Range 0 - 400 ppm Code : 36108</p> <ul style="list-style-type: none"> • EDT018 65ml Plastic Test Bottle • SDT023 BC1/CC1 Indicator • SDT026 BC2 High Range Titrant 	<p>NITRITE TEST KIT</p> <p>Nitrite Range 0 - 3400 ppm Code : 36105</p> <ul style="list-style-type: none"> • EDT007 10ml Test Tube • EDT169 2ml Syringe • SDT072 N1 Indicator • SDT474 N2m Titrant 	<p>P&M ALKALINITY TEST KIT</p> <p>Alkalinity P&M Range 0 - 400 ppm Code : 36104</p> <ul style="list-style-type: none"> • EDT018 65ml Plastic Test Bottle • EDT073 10ml Syringe • SDT001 PA1 Indicator • SDT005 PA2 High Range Titrant • SDT004 TA4 Indicator 
---	--	---



safe seas, safe shores



Vecom Marine
clean ships - clean seas

Maintenance & Cleaning Chemicals

<p>GP DEGREASER</p> <p>General Purpose Emulsifier Cleaner Code : 56098 (25 ltr Drum)</p> <p>A general oil and grease remover for deck and engine room. Most suitable for removal of oil and grease from machinery parts, tank tops, bulkheads, decks and floor plates, and especially for Tank cleaning. It is also used for cleaning of cargo tanks, bunker tanks and for spot cleaning.</p>	<p>HAND CLEANER</p> <p>Removes Heavy Industrial Soiling Code : 34122 (4x4.5 ltr Box)</p> <p>Powerful hand cleaner for removing heavy industrial soiling. Solvent-free formula. Rapidly emulsifies with all types of soil to ensure effective cleaning. Cleans and moisturizes the hands and prevents skin irritation. Have a pleasant fresh fragrance. Available in pumps, dispensers and wall bucket lids.</p>	<p>TANK CLEAN ALKALINE EXTRA</p> <p>Alkaline cleaner/Pet Coke cleaner Code : 56268 (25 ltr Can) Code : 58268 (200 ltr Can)</p> <p>Used for removing hardened oxidized oil and grease deposits and for cleaning pet coke, boiler furnace, etc. It is also used as a final treatment for cleaning tanks from black to white or grain and is safe on epoxy and polyurethane tank coatings.</p>
<p>QUICK SPLIT CLEANER</p> <p>Separating Tank and General Cleaner Code : 56996 (25 ltr Can)</p> <p>A heavy-duty tank and bilge cleaner. It is used for cleaning and gas freeing of mineral oil tanks and for cleaning of tanks upgrading from black to white or grain. It can also be used as a general cleaner in the engine room and especially for cleaning bilges. It's suitable for removal of most mineral oils, fats, and grease.</p>	<p>ELECTRO CLEAN CF</p> <p>Non-Conductive Electric Cleaner Code : 56383 (25 ltr Can)</p> <p>Used as a special de-greasing agent for removal of oil & grease from electrical components, machine parts, ball bearings, etc. It is odorless and evaporates without leaving residue. It does not contain chlorinated hydrocarbons or harmful chemicals and does not emulsify in water. It has a high flash point.</p>	<p>MULTI CLEANER</p> <p>Biodegradable Cleaner Code : 56173 (25 ltr Can)</p> <p>A superior liquid detergent with good foaming properties. The active wetting agents give rapid penetration to remove light oil and dirt from all surfaces. It is used in the galley, accommodation and engine room aboard ships, launches and maintenance department of all industries. Also used for cleaning reefer boxes, woodwork and decks.</p>
<p>RUST REMOVER</p> <p>IMO Approved Rust Cleaner Code : 56214 (25 ltr Can)</p> <p>An excellent tank cleaner for removing oxides, chlorides, nitrates, amides, amines, and other salts. Useful for cleaning the white powders appearing after loading vegetables and fatty acid oil additives. It also removes lime deposits that can occur after hot seawater washing. It cleans and brightens metals and forms a protective coating on treated surfaces. It's biodegradable and non-flammable.</p>	<p>AIR COOLER CLEANER</p> <p>Cleaner & Corrosion Inhibitor Code : 56001 (25 ltr Drum)</p> <p>A liquid cleaner containing solvents and surface-active agents for on-line and off-line cleaning of charge air coolers. It has been developed for safe, fast and economical in-service cleaning of the air handling systems of turbo charged diesel engines. By using ACC, airborne contaminants that have been carried into and deposited on scavenger air trunks, air coolers and inlet valves are removed.</p>	<p>CARBON REMOVER NC</p> <p>Solvent Emulsifier Code : 56924 (25 ltr Drum)</p> <p>Used undiluted for breaking down and separating residual combustion products and by-products of distillation of mineral oils. It's suitable for cleaning burner tips, lube/fuel oil filters, oil coolers, fuel injectors and machines parts. It quickly dissolves deposits containing carbon, resins or varnishes and eliminates the need for hand scraping.</p>



safe seas, safe shores



Vecom Marine
clean ships - clean seas

MARINE CHEMICALS & TEST KITS

<p>DESCALER POWDER</p> <p>Descaling and Anti-Corrosion Powder Code : 35107 (25 kg Bucket)</p> <p>A water soluble acid powder suitable for removing water scale and rust in diesel engine cooling water systems, boilers, evaporators, condensers etc. Being a powder product, it offers safe handling and easy storage.</p>	<p>MARISOL</p> <p>Water-Based Cleaning Agent Code : 56299 (25 ltr Can)</p> <p>Contains alkaline salts and surfactants, designed for high pressure cleaning machines, tank cleaning of vegetable, animal, and mineral oil residues, and for de-greasing heat exchangers, condensers, etc.</p>	<p>TANK CLEAN HD SPLIT</p> <p>Strong Emulsifying Cleaning Agent Code : 56245 (25 ltr Drum)</p> <p>A strong emulsifying cleaning agent suitable for cleaning of heavy fuel oils, lube oils, grease, bitumen residues etc., from cargo storage tanks, pipeline systems, engine rooms, pump rooms etc.</p>
<p>SEACLEAN VOYAGE</p> <p>Fast and Effective Tank Cleaner Code : 56243 (25 ltr Drum) Code : 58243 (200 ltr Drum)</p> <p>Used for cleaning and gas freeing cargo tanks contaminated with petroleum residues, double bottom tanks, deep tanks and bilges. Can be used neat or diluted with water, through machines, manual spraying, rock & roll, etc.</p>	<p>ECOSPERSER</p> <p>Anti-Foulant & Corrosion Inhibitor Code : 56236 (25 ltr Can)</p> <p>Gives complete protection against corrosion and fouling by marine growth such as algae, moss, shellfish and micro-organisms in seawater cooling systems. It is also used to treat diesel engine closed cooling water systems against contamination of micro-organisms.</p>	<p>DESCALING LIQUID EXTRA</p> <p>Descaling and Anti-Corrosion Liquid Code : 56108 (25 ltr Can)</p> <p>A heavy duty acid compound suitable for removal of hardness scale and/or iron oxides from boilers, condensers, evaporators, heat exchangers, cooling systems etc. It must not be used on zinc, aluminum, galvanized materials, cast iron and stainless steel.</p>
<p>MICROZYME SEWAGE</p> <p>Sanitation Treatment and Cleaner Code : 56429 (25 ltr Can)</p> <p>A concentrated blend of liquid living aerobic and anaerobic bacteria which accelerate the degradation of sanitation wastes. It stops sanitation wastes, grease, fat from accumulating in drain systems. It eliminates foul odors and deodorizes ship sanitation systems.</p>	<p>OSD READY TO USE</p> <p>Ready-for-use Oil Spill Dispersant Code : 56334 (25 ltr Can)</p> <p>The environmental solution for oil pollution in the sea. This efficient dispersant can be used for a wide range of oils, converting the oil slick into small droplets which are rapidly distributed within the sea due to natural water movement.</p>	<p>GP ENVIRO</p> <p>Water-Based De-greaser Code : 56427 (25 ltr Can)</p> <p>Used for enviro tank cleaning and engine room cleaning. An alternative of GP Degreaser in a water based formulation. Deck / Bulk head and accommodation are the areas where it can be used as a general cleaner. It is biodegradable and non-flammable.</p>
<p>OIL SPILL DISPERSANT TYPE 1</p> <p>Tank Cleaner: Crude Oil & Paraffin Code : 56425 (25 ltr Drum)</p> <p>Used to disperse and clear accidental oil spills on deck and in the sea. It rapidly converts hydrocarbons into very fine emulsions accelerating the breakdown of the oil by marine bacteria. It is biodegradable and has very low toxicity to marine life.</p>	<p>ECOCLEAN</p> <p>Biodegradable Multipurpose Cleaner Code : 56702 (25 ltr Can)</p> <p>An environmentally friendly water-based product that has high degreasing properties. When mixed in different concentrations, can be used for many purposes: removal of grease, sludge, vegetable and animal oils, engine room cleaning, cargo tank cleaning, etc.</p>	<p>All chemicals available ex-stock across SHM's global distribution network</p>



safe seas, safe shores

Solenoid Valve for Co₂ Fire Suppression System



Technical Specifications :



Valve Seat	: Ø12 mm
Max. Working Pressure	: 250 bar
Inlet	: EN25
Outlet	: W21.8x1/14"
Activation	: Electrically, manually, pneumatically
Electr. Activation	: 24 VDC / 0.4 A
Approval	: VdS, LPCB

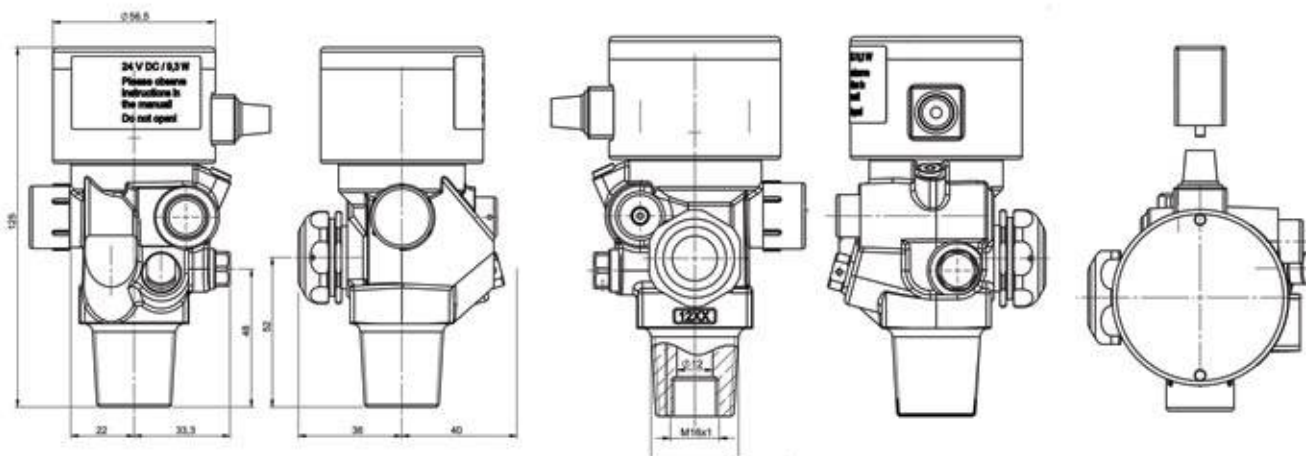

Manual Actuator



Pneumatic Actuator





safe seas, safe shores

Slave Valve for Co₂ Fire Suppression System



Technical Specifications :



Valve Seat	: Ø12 mm
Max. working Pressure	: 250 bar
Inlet	: EN25
Outlet	: W21.8x1/14"
Activation	: Manually, pneumatically
Approval	: VdS, LPCB

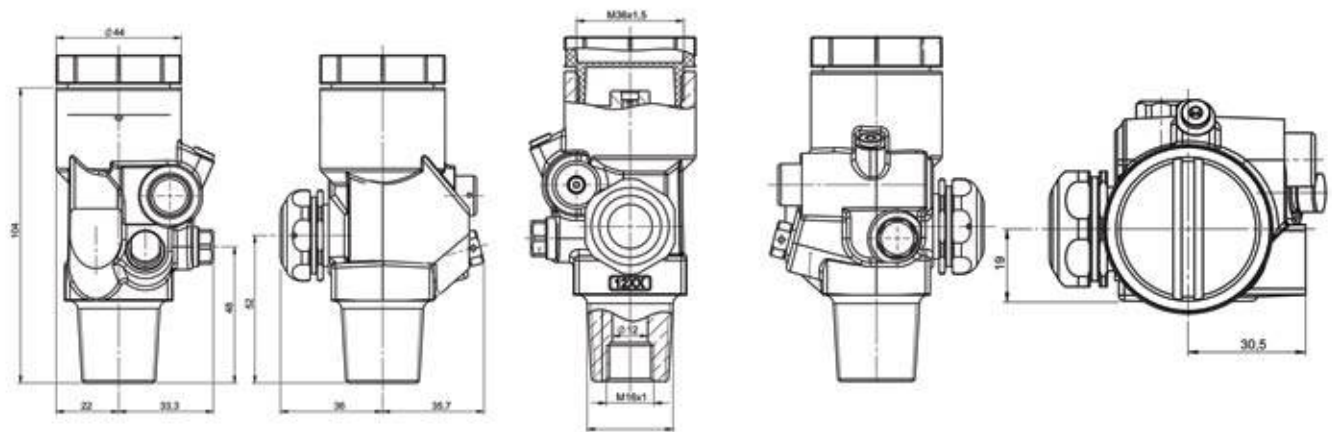

Pneumatic / Manual Actuator

Pneumatic Actuator

Manual Actuator



Fiwarec Valves & Accessories is available ex-stock through SHM's global distribution network

Disposal of Time Expired Pyrotechnics

DG Shipping LSA Circular 1 of 2015 highlights

Pyrotechnics need to be landed ashore as soon as they expire and disposed off in an environment friendly manner to prevent their misuse and recycling. In view of this, the Nautical Wing of DG Shipping, Govt. of India, issued LSA Circular 1 of 2015 which states,

“...time expired Pyrotechnics which were intended for use on board ships and survival crafts are being misused, fraudulently by way of tampering with the dates of expiry... it was reported that such malpractices are being practiced by the life raft stations and suppliers of pyrotechnics...Considering the fact that the pyrotechnics are essential life saving appliance on board ships, in case of distress at sea, any malpractice will jeopardize the safety of lives at sea.

...The shipping companies, suppliers and life rafts stations are hereby reminded of their responsibility to ensure use of genuine pyrotechnics...such agencies are directed to ensure disposal...through suitable facilities which are either controlled by the Government Organization or approved by the Petroleum and Explosives Safety Organization (PESO)...defaulters may be prosecuted which may amount to a penalty as imprisonment which can extend up to six months.”

SHM's PESO approved disposal facility in Vishakhapatnam

In compliance to above DGS circular and in line with SHM's core value of sustainability, we have established a facility (our group company M/s. Balaji Marine and Civil Engineering Works, Visakhapatnam) for disposal of expired pyrotechnics duly approved and controlled by PESO. We undertake disposal of time expired pyrotechnics as per our principal manufacturer's guidelines and under the supervision of PESO.

SHM's Vision of creating "safe seas, safe shores"

At SHM our vision is "safe seas, safe shores" and we strive to become the leaders in creating safer and secure working environments that enable businesses' freedom at sea and on shore. We will achieve this by partnering with our customers to increase their productivity, fuel their sustainable growth by providing the most reliable safety products and engineering solutions, and having a positive impact on the world around us and on people's lives.

Procedure for disposal



*Contact numbers of SHM's Collection Centres are listed on the back page



Disposal of Hand Flare at Vishakhapatnam facility

WARNING :



- Never fire Pyrotechnics on land, in harbor, or at sea for either testing purposes, practice, or as fireworks

- Never dump Pyrotechnics at sea



- Never keep Pyrotechnics after the date of the expiry

- Never place expired pyrotechnics in the general waste, where they can be accessed by general public



SHM's Time Expired Pyrotechnic Collection Centers



safe seas, safe shores



For enquiries and service support please contact us at pyrodisposal@shmgroup.com

OUR LOCATIONS



MUMBAI
T : +91 22 2378 6400 / 401 / 402
F : +91 22 2374 4922 / 2379 2125
E : mumbai@shmgroup.com

KOLKATA
T : +91 33 24594 761 / 762
F : +91 33 2459 6626
E : kolkata@shmgroup.com

KOCHI
T : +91 484 2703764 / 65
F : +91 484 2703765
E : kochi@shmgroup.com

VIZAG
T : +91 891 256 5227 / 8307
F : +91 891 2561804
E : vizag@shmgroup.com

KANDLA
T : +91 2836 232116
F : +91 2836 232544
E : kandla@shmgroup.com

CHENNAI
T : +91 44 2590 1322 / 1679
F : +91 44 42173327
E : chennai@shmgroup.com

PORT BLAIR
T : +91 3192 231941
F : +91 3192 231 940
E : portblair@shmgroup.com

SINGAPORE
T : +65 62806408
E : singapore@shmgroup.com

DUBAI
T : +971 4276 6537
F : +971 4276 6519
E : dubai@shmgroup.com

PORT KLANG
T : +603 3373 8254
E : malaysia@shmgroup.com

NEW DELHI
T : +91 9990 4691 70 / 9310 3399 34
E : delhi@shmgroup.com

PARADEEP
T : +91 6722 2200 49
F : +91 6722 2200 49
E : paradeep@shmgroup.com

AHMEDABAD
T : +91 9033 3044 88
E : ahmedabad@shmgroup.com

SHANGHAI
T : +86 1390 1794 473
E : china@shmgroup.com

Enabling your freedom at sea

“Enabling freedom at sea” stands for SHM’s commitment of offering our clients peace of mind – at sea and on shore. It talks about the peace of mind you have when you know that someone you trust is taking care of you. It talks about what safety enables you to do:

- Freedom to operate
- Freedom to trade
- Freedom to travel
- Freedom to explore
- Freedom to innovate
- Freedom to excel

The SHM logo consists of the letters "SHM" in a bold, white, sans-serif font, centered within an orange, irregular shape that resembles a stylized wave or a banner.

safe seas, safe shores

Global Head Office:
B.P.T., Plot No. 51, 1st Lane, Ground Floor,
Magazine Street, Darukhana, Mazagaon,
Mumbai - 400 010.
T : 91 22 2378 6400 / 401 / 402
F : 91 22 2379 2125
E : admin@shmgroup.com
W : www.shmgroup.com

